

**TECHNICAL MANUAL  
OPERATOR AND UNIT MAINTENANCE MANUAL  
INCLUDING REPAIR PARTS AND SPECIAL TOOLS  
LIST**

**PERSONNEL INSERTION/EXTRACTION SYSTEMS  
FOR STABO**

**(NSN 1670-00-168-5952, NSN 1670-00-168-6064,  
NSN 1670-00-168-6063)**

**FAST ROPE INSERTION/EXTRACTION SYSTEM  
(NSN 4020-01-338-3307, NSN 4020-01-338-3308,  
NSN 4020-01-338-3309)**

**AND**

**ANCHORING DEVICE  
(NSN 1670-00-999-3544)**

**This copy is a reprint which includes  
current pages from changes 1 and 2.**

**Approved for public release; Distribution is unlimited.**

**\*This manual supersedes TM 10-1670-262-12, dated August 1970.**

---

**HEADQUARTERS, DEPARTMENT OF THE ARMY  
25 SEPTEMBER 1992**

CHANGE  
NO. 2

HEADQUARTERS  
DEPARTMENT OF THE ARMY  
WASHINGTON, D.C., 30 June 1994

**Operator and Unit Maintenance Manual  
Including Repair Parts and Special Tools List**

**PERSONNEL INSERTION/EXTRACTION SYSTEMS  
FOR STABO**

**(NSN 1670-00-168-5952, NSN 1670-00-168-6064, NSN 1670-00-168-6063)**

**FAST ROPE INSERTION/EXTRACTION SYSTEM**

**(NSN 4020-01-338-3307, NSN 4020-01-338-3308, NSN 4020-01-338-3309)**

**AND**

**ANCHORING DEVICE (NSN 1670-00-999-3544)**

DISTRIBUTION STATEMENT A: Approved for public release; distribution is unlimited.

TM 10-1670-262-12&P, 25 September 1992, is changed as follows:

1. Remove and insert pages as indicated below. New or changed text material is indicated by a vertical bar in the margin. An illustration change is indicated by a miniature pointing hand.

Remove pages

Insert pages

1-7 and 1-8

1-7 and 1-8

Index 1 and Index 2

Index 1 and Index 2

2. Retain this sheet in front of manual for reference purposes.

**By Order of the Secretary of the Army:**

**GORDON R. SULLIVAN**  
*General, United States Army*  
*Chief of Staff*

Official:



**MILTON H. HAMILTON**

*Administrative Assistant to the*  
*Secretary of the Army*

06838

**DISTRIBUTION:**

To be distributed in accordance with DA Form 12-25-E, block no. 5969,  
requirements for TM 10-1670-262-12&P.

URGENT

TM 10-1670-262-12&P  
C1

CHANGE  
NO. 1

HEADQUARTERS  
DEPARTMENT OF THE ARMY  
WASHINGTON, D.C., 24 NOVEMBER 1993

**OPERATOR AND UNIT MAINTENANCE MANUAL  
INCLUDING REPAIR PARTS AND SPECIAL TOOLS LIST  
PERSONNEL INSERTION/EXTRACTION SYSTEMS  
FOR STABO**

(NSN 1670-00-168-5952, NSN 1670-00-168-6064, NSN 1670-00-168-6063)

**FAST ROPE INSERTION/EXTRACTION SYSTEM**

(NSN 4020-01-338-3307, NSN 4020-01-338-3308, NSN 4020-01-338-3309)

AND

**ANCHORING DEVICE**

(NSN 1670-00-999-3544)

DISTRIBUTION STATEMENT A: Approved for public release; distribution is unlimited.

TM 10-1670-262-12&P, 25 September 1992, is changed as follows:

1. Remove and insert pages as indicated below. New or changed text material is indicated by a vertical bar in the margin. An illustration change is indicated by a miniature pointing hand.

Remove pages	Insert pages
a/(b blank)	a/(b blank)
i and ii	i and ii
2-11 and 2-12	2-11 and 2-12.
C-17 and C-18	C-17 and C-18

2. Retain this sheet in front of manual for reference purposes.

**By Order of the Secretary of the Army:**

Official:

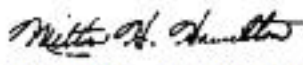
  
**MILTON H. HAMILTON**  
Administrative Assistant to the  
Secretary of the Army  
05838

**GORDON R. SULLIVAN**  
General, United States Army  
Chief of Staff

DISTRIBUTION:

To be distributed in accordance with DA Form 12-25-E, block no. 5969, requirements for TM 10-1670-262-12&P.

**WARNING**

Personnel performing instructions involving operations, procedures, and practices which are included or implied in this technical manual shall observe the following instructions. Disregard of these warnings can cause serious injury to personnel or loss of life.

Prior to connecting the bridle snap hooks to the personnel harness, ensure the harness leg straps are in place, connected, and drawn tight.

No flight with extracted personnel suspended below the aircraft, shall exceed 80 KIAS.

When jettisoning, no attempt shall be made to cut a taut suspension rope near or by the extracted personnel, as a stretched rope that is cut could entangle in the rotor blades of the retrieval helicopter.

FIRST AID. For first aid treatment, refer to FM 21-11.

**OPERATOR AND UNIT, MAINTENANCE MANUAL  
INCLUDING REPAIR PARTS AND SPECIAL TOOLS LIST  
PERSONNEL INSERTION/EXTRACTION SYSTEMS  
FOR STABO**

(NSN 1670-00-168-5952, NSN 1670-00-168-6064, NSN 1670-00-168-6063)

**FAST ROPE INSERTION/EXTRACTION SYSTEM**

(NSN 4020-01-338-3307, NSN 4020-01-338-3308, NSN 4020-01-338-3309)

**AND**

**ANCHORING DEVICE (NSN 1670-00-999-3544)**

**REPORTING ERRORS AND RECOMMENDING IMPROVEMENTS**

You can help improve this manual. If you find any mistakes or if you know of a way to improve the procedures, please let us know. Mail your letter, DA Form 2028 (Recommended Changes to Publications and Blank Forms), or DA Form 2028-2 located in back of this manual direct to: Commander, US Army Aviation and Troop Command, ATTN: AMSAT-I-M P, 4300 Goodfellow Blvd., St. Louis, MO 63120-1798. A reply will be furnished to you.

DISTRIBUTION STATEMENT A: Approved for public release; distribution is unlimited.

**TABLE OF CONTENTS**

			<b>PAGE</b>
CHAPTER	1	INTRODUCTION .....	1-1
Section	I	General Information .....	1-1
Section	II	Equipment Description and Data .....	1-2
Section	III	Principles of Operation .....	1-10
CHAPTER	2	OPERATING INSTRUCTIONS .....	2-1
Section	I	Description and Use of Operator's Controls and Indicators .....	2-1
Section	II	Operator Preventive Maintenance Checks and Services (PMCS) .....	2-1
Section	III	Operation Under Usual Conditions .....	2-3
Section	IV	Operation Under Unusual Conditions .....	2-11

\* This manual supersedes TM10-1670-262-12, dated August 1970.

TABLE OF CONTENTS - continued

			PAGE	
CHAPTER	3	UNIT MAINTENANCE INSTRUCTIONS .....	3-1	
Section	I	Repair Parts; Special Tools; Test, Measurement, and Diagnostic Equipment (TMDE); and Support Equipment .....	3-1	
Section	II	Service Upon Receipt of Material .....	3-1	
Section	III	Packing Procedures .....	3-5	
Section	IV	Unit Preventive Maintenance Checks and Services (PMCS) .....	3-9	
Section	V	Maintenance Procedures .....	3-11	
Section	VI	Preparation for Storage and Shipment .....	3-24	
APPENDIX	A	REFERENCES .....	A-1	
APPENDIX	B	MAINTENANCE ALLOCATION CHART .....	B-1	
			Page	
			Illust/ Figure	
APPENDIX	C	REPAIR PARTS AND SPECIAL TOOLS LIST .....	C-1	
Section	I	Introduction .....	C-1	
Section	II	Repair Parts .....	C-8	
Group	01	Anchoring Device/Cargo and Personnel.....	C-9	C-1
Group	02	Strap, Cargo Lowering .....	C-11	C-2
Group	03	Personnel Stabilized Body Extraction System .....	C-13	C-3
Group	04	Fast Rope, Insertion/Extraction System .....	C-15	C-4
Group	05	Bulk Material .....	C-16	
Section	III	Special Tools List (Not Applicable)		
Section	IV	National Stock Number/Part Number Index .....	C-17	
		Figure and Item Number Index .....	C-18	
APPENDIX	D	EXPENDABLE/DURABLE SUPPLIES AND MATERIALS LIST .....		D-1
		INDEX .....		Index-1

## CHAPTER 1

## INTRODUCTION

## Section I. GENERAL INFORMATION

**1-1. Scope.**

This manual is published for use by operator and unit maintenance personnel responsible for operating and performing maintenance on the personnel stabilized body (STABO) insertion/extraction system and the fast rope extraction system. Additional instructions are also furnished for the installation of the cargo and personnel lowering anchoring device on the UH-1 aircraft.

**1-2. Maintenance Forms and Records.**

Department of the Army forms and procedures used for equipment maintenance will be those prescribed by DA PAM 738-750, The Army Maintenance Management System.

**1-3. Reporting of Equipment Improvement Recommendations (EIRs).**

If your lowering device needs improvement, let us know. Send us an EIR. You, the user, are the only one who can tell us what you don't like about your equipment. Let us know why you don't like the design or performance. Put it on an SF368 Quality Deficiency Report (QDR). Mail it to us at: Commander, U.S. Army Troop Support Command, ATTN: AMSTR-MOF, 4300 Goodfellow Blvd., St Louis, MO 63120-1798. We will send you a reply.

**1-4. Destruction of Army Materiel to Prevent Enemy Use.**

Destruction methods are described in the following subparagraphs.

a. General.

- (1) Objective. Methods of destruction used to inflict damage on air delivery equipment make it impossible to restore equipment to a usable condition in a combat zone by either repair or cannibalization.
- (2) Authority. Destruction of air delivery equipment that is in imminent danger of capture by an enemy is a command decision that must be made by a battalion or higher commander or the equivalent.
- (3) Implementation plan. All units which possess air delivery equipment should have a plan for the implementation of destruction procedures.
- (4) Training. All personnel who use or perform such functions as rigging, packing, maintenance, or storage of air delivery equipment should receive thorough training on air delivery equipment destruction procedures and methods. The destruction methods demonstrated during training should be simulated. Upon completion of training, all applicable personnel should be thoroughly familiar with air delivery equipment destruction methods and be capable of performing destruction without immediate reference to any publication.



**1-4. Destruction of Army Materiel to Prevent Enemy Use - continued.**

- (5) Specific methods. Specific methods of destroying Army materiel to prevent enemy use shall be by mechanical means, fire, or by use of natural surroundings.

b. Destruction by Mechanical Means. Air delivery equipment metal assemblies, parts, and packing aids shall be destroyed using hammers, bolt cutters, files, hacksaws, drills, screwdrivers, crowbars, or other similar devices to smash, break, bend, or cut.

**WARNING**

**Exercise extreme care when using petroleum products to destroy equipment by fire, as severe burns or death could result.**

c. Destruction by Fire. Items that can be destroyed by fire shall be burned. The destruction of equipment by use of fire is an effective method of destroying low-melting-point metal items (e.g., side rails, threaded portions of nuts and bolts, and platform sheeting). However, mechanical destruction should be completed first, whenever possible, before initiating destruction by fire. When items to be destroyed are made of metal, textile materials (or some comparable low combustible material) should be packed under and around the items, then soaked with a flammable petroleum product and ignited. Proper concentration of equipment which is suitable for burning will provide a hotter and more destructive fire.

d. Destruction by Use of Natural Surroundings. Small vital parts of assemblies which are easily accessible may be disposed of as follows: Disposal or denial of equipment to an enemy may be accomplished through use of natural surroundings. Accessible vital parts of assemblies may be removed and scattered through dense foliage, buried in dirt or sand, or thrown into a lake, stream, or other body of water. Total submersion of equipment in a body of water will provide water damage as well as concealment. Saltwater will inflict extensive damage to air delivery equipment.

**Section II. EQUIPMENT DESCRIPTION AND DATA****1-5. Equipment Characteristics, Capabilities, and Features.**

Characteristics, capabilities, and features of the equipment are as follows:

a. The Personnel STABO Extraction System.

- (1) Personnel harness. The personnel harness (fig. 1-1) is made of nylon webbing and stitched to a standard medium or large sized web pistol belt (4). The harness shoulder strap (3) is constructed in small, medium, and large sizes with leg straps (7) that may be adjusted to the comfort of the user. Each leg strap has an adjustable snap hook (6) which connects to the related leg strap connector V-ring (5). The harness possesses two web adjusters (1) for adjusting the harness webbing to individual size. An equipment attaching ring is positioned above each web adjuster on the front of the harness sling. Additionally, the harness has two lift V-rings (2) installed at the top of each of the harness shoulder straps, which connect to the bridle snap hooks and provide a lift point for the harness.

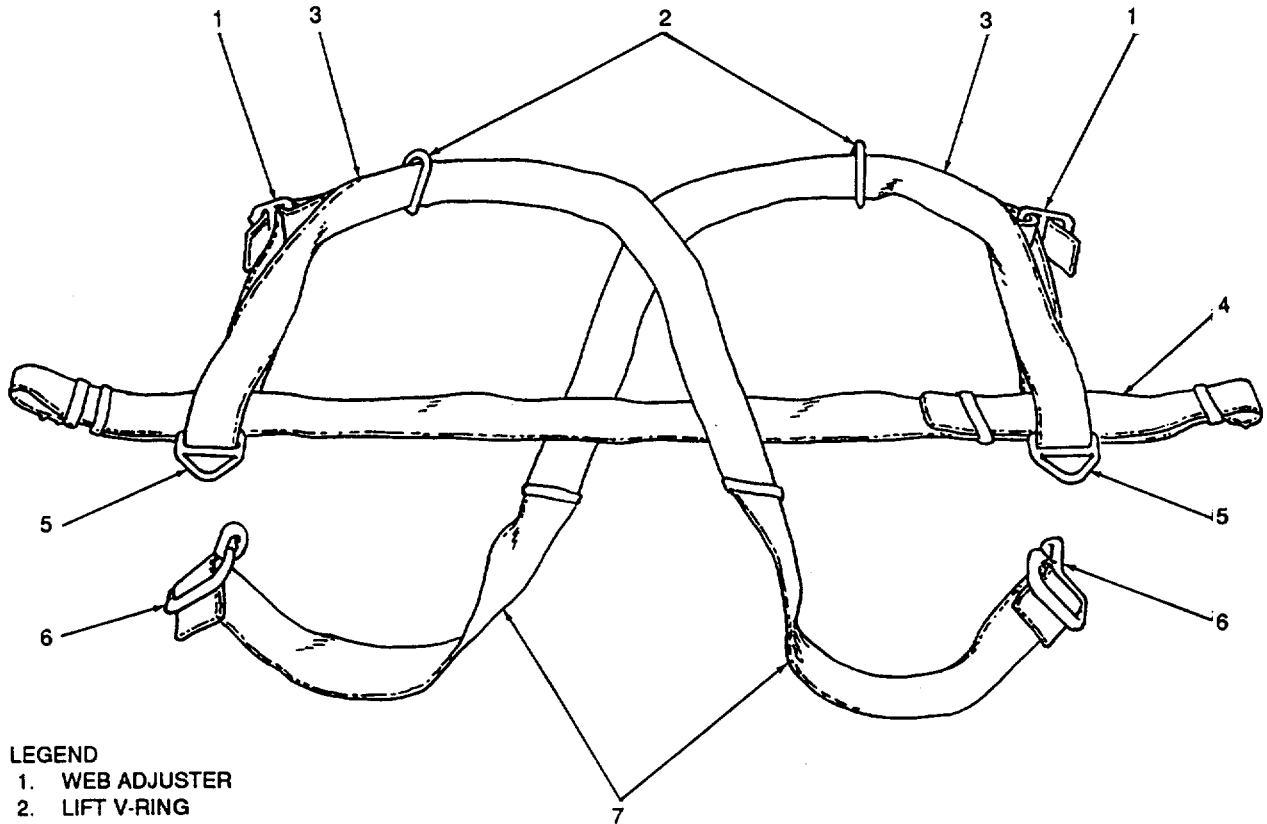

**LEGEND**

- 1. WEB ADJUSTER
- 2. LIFT V-RING
- 3. HARNESS SHOULDER STRAP
- 4. WEB PISTOL BELT
- 5. LEG STRAP CONNECTOR V-RING
- 6. ADJUSTABLE SNAP HOOK
- 7. LEG STRAP

**Figure 1-1. The Personnel Harness, Typical.**

**1-5. Equipment Characteristics, Capabilities, and Features - continued.**

- (2) Bridle. The bridle (fig. 1-2) is made of nylon webbing with a V-shape design. A D-ring (1) is located on the single end of the bridle body (2) and a snap hook (3) is secured to each of the two bridle running ends. During use, the D-ring is connected to a suspension rope snap hook while the two bridle snap hooks are attached to the two personnel harness lift V-rings.

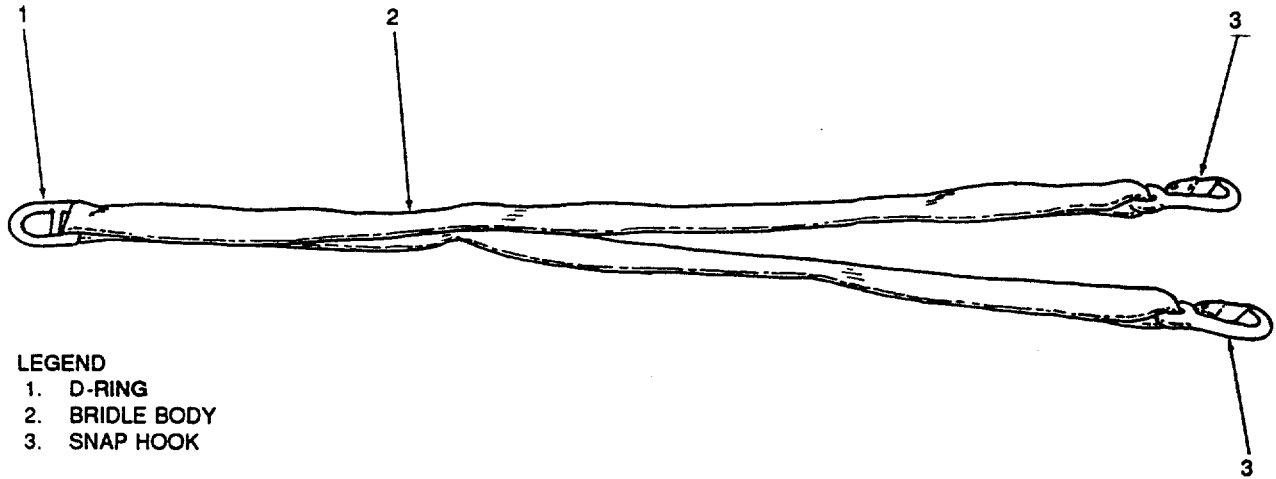

**Figure 1-2. The Bridle.**

- (3) Suspension rope. The suspension rope is 147-feet long and made of nylon. Each end of the rope (fig. 1-3) is looped and spliced. A snap hook (1) is attached to each of the rope end spliced loops (2). The suspension rope is designed to connect on one end to an anchoring device installed in a helicopter while the opposite end is attached to the bridle D-ring.
- (4) Safety rope. The safety rope (fig. 1-3) is 12-feet long and made of nylon. Each end of the rope is looped and spliced with a snap hook (1) attached to each spliced loop (2). The safety rope is used when extracting two or three personnel and provides a means for the individuals concerned to hold together, thereby minimizing possible wind buffeting and oscillation which may occur during pickup and flight.

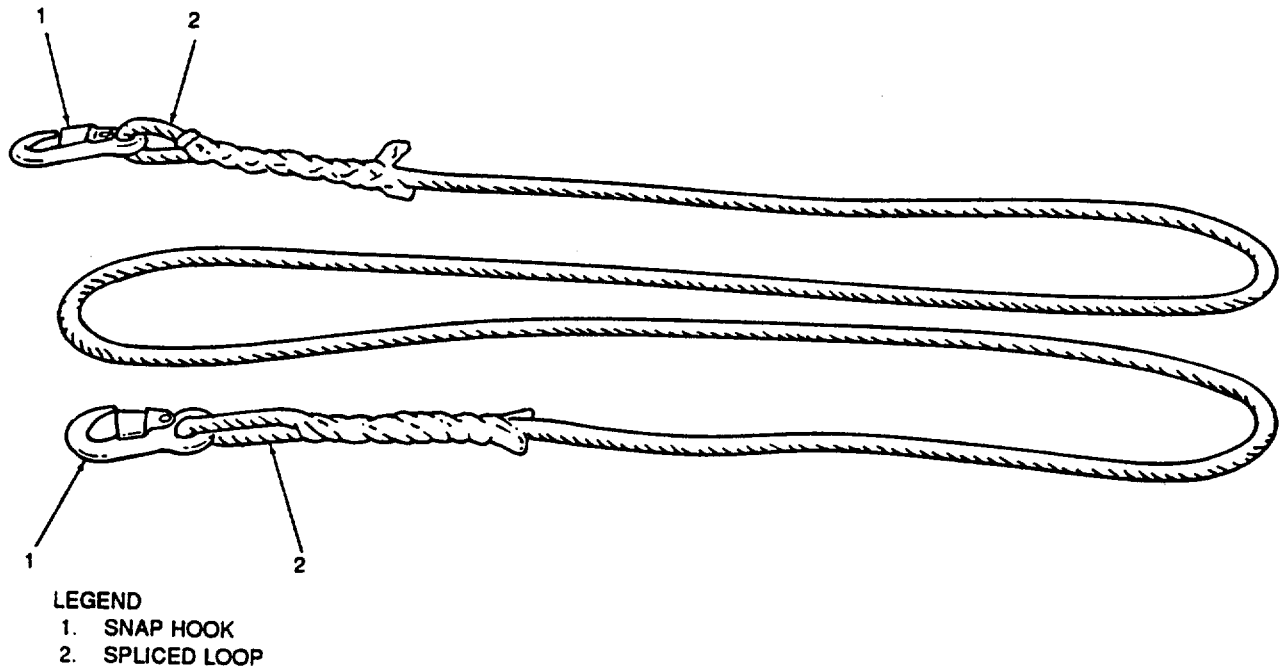
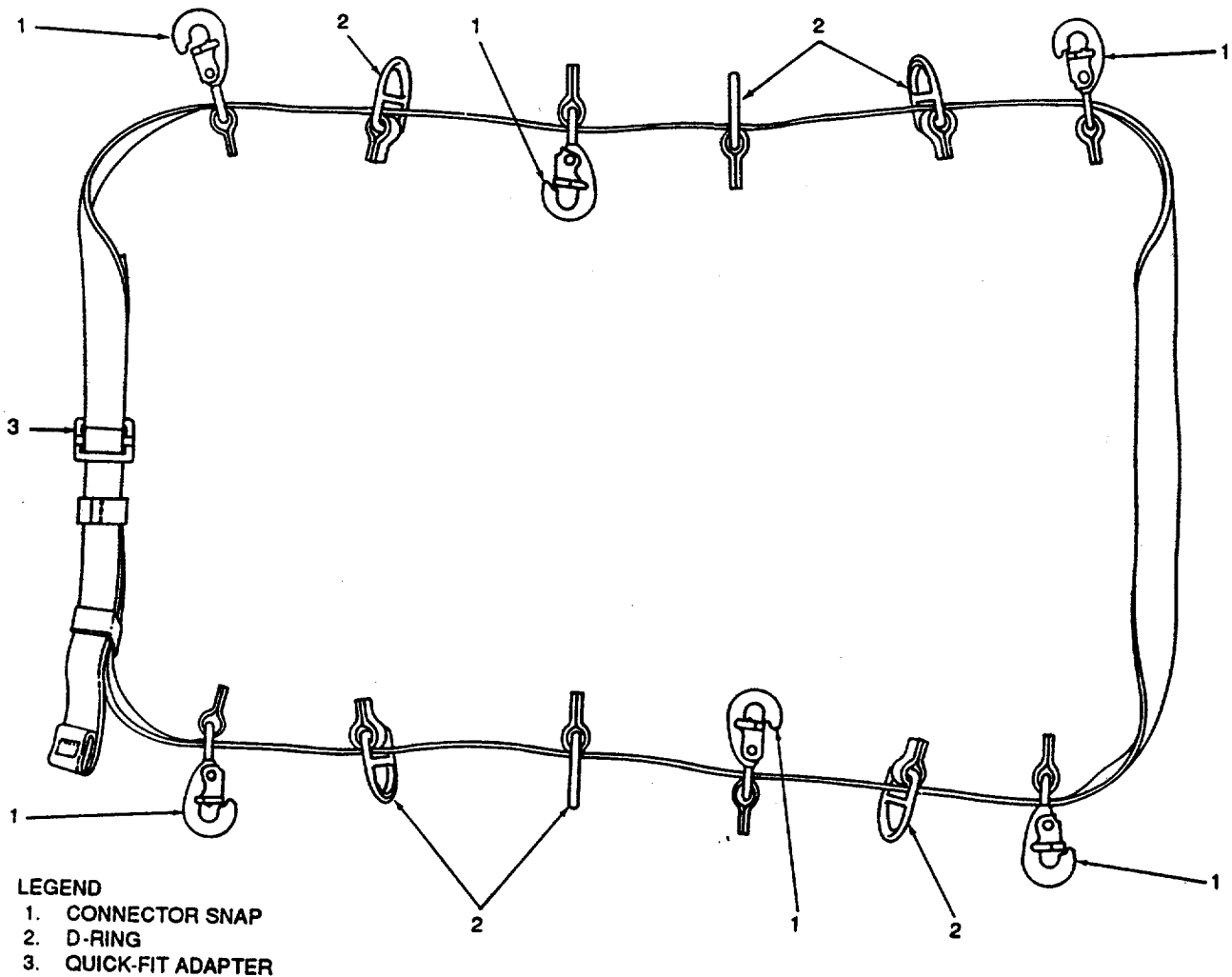

Figure 1-3. The Suspension and Safety Ropes, Typical

**1-5. Equipment Characteristics, Capabilities, and Features - continued.**

b. Cargo and Personnel Lowering Anchoring Device. The anchoring device consists of a 13-foot long nylon web floor tiedown loop (fig. 1-4) and three 87 3/4-inch long nylon strap assemblies (fig. 1-5). The web loop has six sliding connector snaps (1, fig. 1-4) attached which connect to specified tiedown fittings in the aircraft floor. The web loop may accommodate any number of sliding D-rings (2) which provide an attachment point for the strap assemblies. Three sliding D-rings are required to be attached to the web loop when the anchoring device is to be used with the STABO extraction system.



**Figure 1-4. Web Loop, Typical**

c. Fast Rope. The fast rope (fig. 1-6) is a polyester rope, which is 1 3/4 inches in diameter, olive drab in color, and is issued in 60-foot, 90-foot, and 120-foot lengths. The top of the main rope (1) has an eight inch eye splice to allow the rope to be attached to specially equipped helicopters. At the bottom of the main rope, 9/16-inch diameter white nylon rope is spliced into the main rope to form three extraction loops (2). A 9/16-inch diameter black nylon rope is also spliced into the main rope to form three safety loops (3) at the same position as the extraction loops.

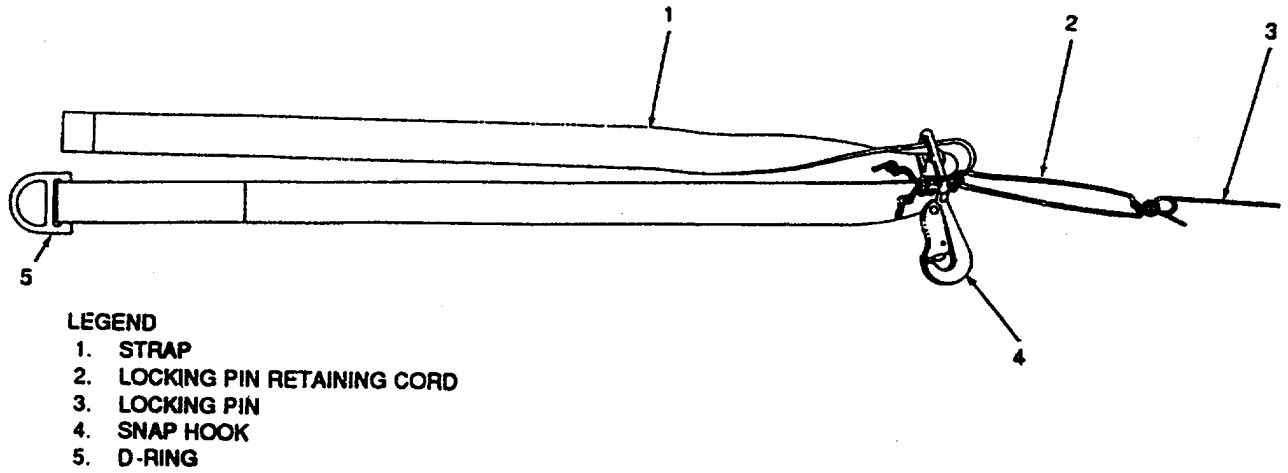

Figure 1-5. The Strap Assembly.

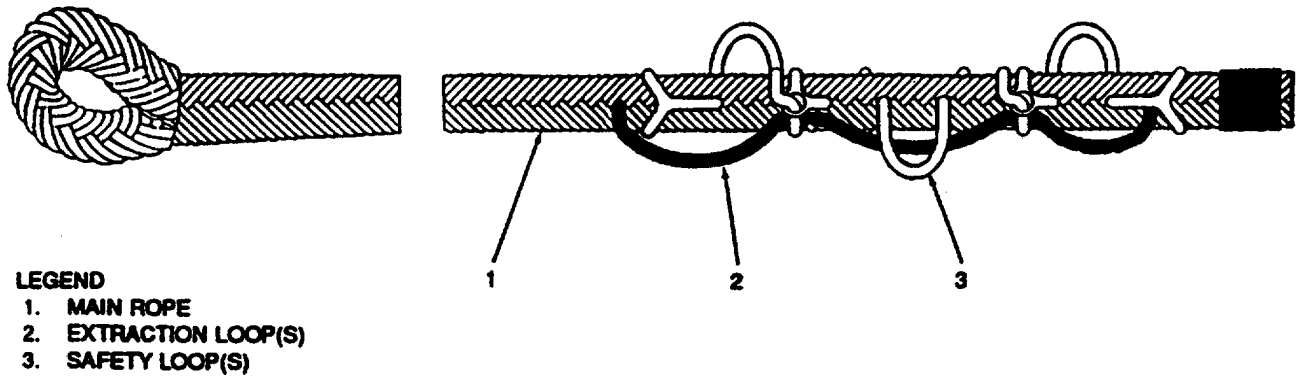

Figure 1-6. The Fast Rope.

1-6. Deleted.



**1-7. Location and Description of Major Components.**

- a. Deployment Bag (fig. 1-7). The bag, when packed, contains the suspension rope, bridle, and safety rope.

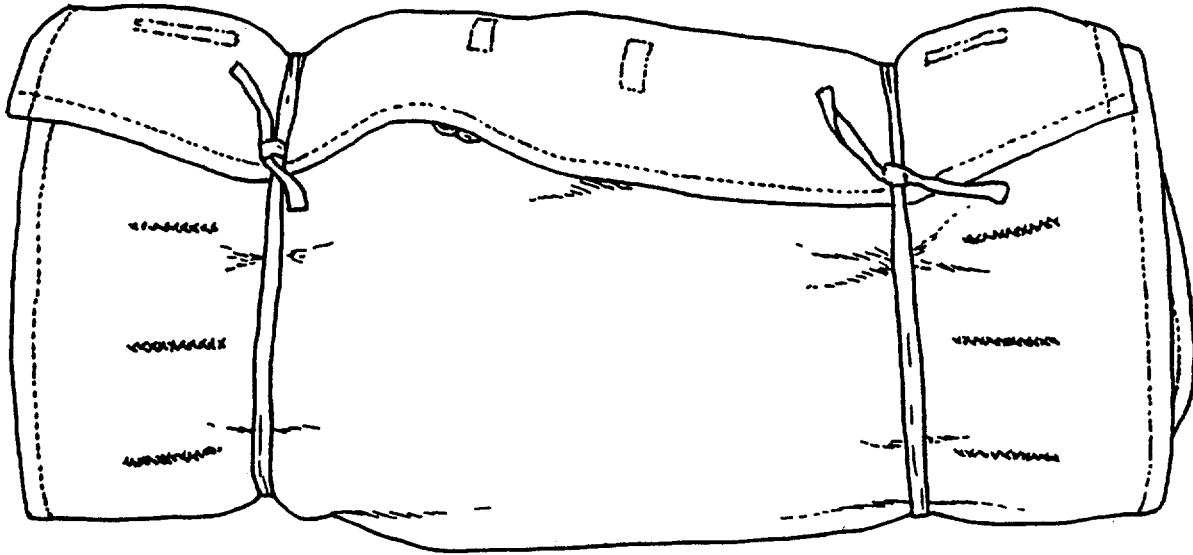

**Figure 1-7. The Deployment Bag.**

- b. Fast Rope (fig. 1-6). Made from polyester rope, 1 3/4 in. diameter. An 8 in. spliced loop at the top allows the rope to be attached to specially equipped helicopters.
- c. Personnel Harness (fig. 1-1). Made from nylon webbing. Fits around wearer's waist and legs. Primarily used in self-lowering.
- d. Suspension Rope (fig. 1-3). Made from nylon 147 ft long and 3/8 in. diameter. Feeds from deployment bag.

### **1-8. Safety, Care and Handling.**

- a. Safety. It is imperative that all safety precautions specified on the warning page in the front of the manual be observed. Also observe specific warnings and cautions specified throughout this manual. The warnings are provided for protection from death or serious injury.
- b. Care and Handling.
  - (1) Protect the lowering device from the weather elements, dust, dirt, oil, grease, acids, and direct sunlight.
  - (2) Use a heated building, when available, to store lowering device. Store lowering device in a dry, well-ventilated location, protected from pilferage, dampness, fire, dirt, insects, rodents, and direct sunlight.



### Section III. PRINCIPLES OF OPERATION

#### **1-9. General.**

This section contains a functional description of the personnel STABO extraction system and the fast rope. Also included is the deployment bag, which is utilized to carry all the ropes.

#### **1-10. Personnel STABO Extraction System.**

The personnel STABO extraction system is used with the cargo and personnel lowering anchoring device to provide a means of rapid pickup of personnel by UH-1 aircraft from areas which prohibit helicopter landings. The personnel harness is worn by personnel on the ground. As the pickup process is initiated, the helicopter hovers over the pickup area at altitudes up to 150 feet above the ground. After ensuring the applicable end of the extraction system suspension rope is connected to the anchoring device installed in the aircraft, a member of the aircraft crew drops the extraction system deployment bag from the left side door of the aircraft. A maximum of three extraction system units may be connected and dropped simultaneously, which will allow the extraction of three individuals on one flight. As the deployment bag descends, the suspension rope deploys until the bag reaches the ground. The individual to be extracted then attaches the two bridle snap hooks to the lift V-rings on his harness and after assuring the leg straps are connected and tight, notifies the aircraft by radio or hand signals that lift-off may begin. The helicopter then lifts the individual(s) from the area and, with the retrieved personnel suspended beneath the aircraft, moves to an area where a safe landing can be made. The helicopter then lowers the suspended personnel to the ground, lands, and allows the personnel to board the aircraft.

#### **NOTE**

**Each suspension rope is capable of suspending one individual weighing 240 pounds. The maximum total static weight that may be suspended in-flight from one door of the UH-1 is 720 pounds.**

#### **1-11. Fast Rope.**

The fast rope is a polyester rope which is 1 3/4 inches in diameter, olive drab in color, and is issued in 60-foot, 90-foot, and 120-foot lengths. The top of the rope has an 8-inch eye splice to allow the rope to be attached to specially equipped helicopters. At the bottom of the main rope, a 9/16-inch diameter white nylon rope is spliced into the main rope to form three extraction loops. A 9/16-inch diameter black nylon rope is also spliced into the main rope to form three safety loops at the same position as the extraction loops.

#### **1-12. Deployment Bag.**

The deployment bag is made of cotton duck and is of the roll-type closure design. The bag, when packed, contains the suspension rope, bridle, and safety rope. The lower end of the bag has a 1 0-pound ballast weight installed which aids the deployment of the suspension rope from the helicopter.

## CHAPTER 2

## OPERATING INSTRUCTIONS

Section I. DESCRIPTION AND USE OF OPERATOR'S  
CONTROLS AND INDICATORS**2-1. Operator's Controls and Indicators.**

This equipment does not have specific operator's controls and indicators. Refer to paragraph 1-7 and table 2-1.

**Section II. OPERATOR PREVENTIVE MAINTENANCE CHECKS AND SERVICES (PMCS)****2-2. Introduction.**

a. To ensure that the equipment is ready for operation at all times, it must be inspected systematically so defects may be discovered and corrected before they result in serious damage or failure. The necessary preventive maintenance checks and services (PMCS) that are to be performed by operator personnel are listed and described in table 2-1.

b. Before You Operate. Always keep in mind the CAUTIONS and WARNINGS. Perform your Before PMCS.

c. While You Operate. Always keep in mind the CAUTIONS and WARNINGS. Perform your During PMCS.

d. After You Operate. Be sure to perform your After PMCS.

e. If your equipment fails to operate, troubleshoot with proper equipment. Report any deficiencies using the proper forms. See DA PAM 738-750.

**2-3. Operator's Preventive Maintenance Checks and Services.**

a. General. To extend the service life and obtain maximum performance of the equipment, the operator must adhere to the schedule and instructions in table 2-1.

b. Item Number Column. Item numbers in this column indicate the order in which PMCS should be performed. These numbers shall also be used as the item numbers for the TM Number column on DA Form 2404, Equipment Inspection and Maintenance Worksheet, in recording results of PMCS.

c. Interval Column. Items to be inspected are indicated by an interval in the interval column.

d. Location Column. This column contains the name of the item to be checked or serviced.

e. Procedure Column. This column contains the concise procedures required to do the checks and services.

**2-3. Operator's Preventive Maintenance Checks and Services - continued.**

f. Not Fully Mission Capable If: Column. This column contains the criteria that will cause the equipment to be classified as not fully mission capable because of inability to perform its primary mission. An entry in this column:

- (1) Identifies conditions that make the equipment not fully mission capable for readiness reporting purposes.
- (2) Denies use of the equipment until corrective maintenance has been performed.

**Table 2-1. Operator Preventive Maintenance Checks and Services**

Item No.	Interval	Location Item to Check/ Service	Procedure	Not fully mission capable if:
<b><u>PERSONNEL INSERTION EXTRACTION SYSTEM</u></b>				
1	Before	Harness	Inspect for broken or missing stitching; frayed, worn, or cut webbing; bent, broken, rusted, or missing hardware.	Components are damaged or missing.
2	Before	Suspension Rope	Inspect for cuts, abrasions, melting, or fuzzing; bent, broken, rusted, or missing snap hooks.	Components are damaged or missing.
3	Before	Safety Rope	Inspect for cuts, abrasions, melting, or fuzzing; bent, broken, rusted, or missing snap hooks; burrs or foreign materials on snap hooks.	Components are damaged or missing.
4	Before	Bridle	Inspect for broken, loose, or missing stitching; frayed, worn, or cut webbing; bent, broken, rusted, or missing hardware.	Components are damaged or missing.
5	Before	Deployment Bag	Inspect for broken, loose, or missing stitching; broken or damaged web loops; holes and tears; dirt, grease, or foreign material.	Components have tears, dirt, grease, foreign material, or damaged stitching.
<b><u>CARGO AND PERSONNEL LOWERING ANCHORING DEVICE</u></b>				
6	Before	Web Loop	Inspect for broken or missing stitching; frayed, worn, or cut webbing; bent, broken, rusted or missing hardware, burrs on hardware; connector snap operation; dirt, oil, grease on webbing.	Components are damaged or missing.

Table 2-1. Operator Preventive Maintenance Checks and Services - CONT

Item No.	Interval	Location Item to Check/ Service	Procedure	Not fully mission capable if:
7	Before	Strap Assembly	Inspect for broken or missing stitching; frayed, worn, or cut webbing; bent, broken, rusted or missing hardware; burrs on hardware; snap hook operation; missing locking pin; broken or missing locking pin retaining cord.	Components are damaged or missing.
8	Before	Fast Rope  <u>PERSONNEL INSERTION EXTRACTION SYSTEM</u>	Inspect for bums, cut yam, abraded yarns, loose or missing whipping, lines unraveling. missing.	Material is badly worn or whipping is
9	After	Harness	Inspect for broken or missing stitching; frayed, worn, or cut webbing; bent, broken, rusted or missing hardware; foreign material.	Components are damaged or missing.
10	After	Web Loop	Inspect for broken or missing stitching; frayed, worn, or cut webbing; bent, broken, rusted or missing hardware; burrs on hardware; connector snap operation; dirt, oil, grease on webbing.	Components are damaged or missing.
11	After	Strap Assembly	Inspect for broken or missing stitching; frayed, worn, or cut webbing; bent, broken, rusted or missing hardware; burrs on hardware; snap hook operation; missing locking pin; broken or missing locking pin retaining cord.	Components are damaged or missing.
12	After	Fast Rope	Inspect for bums, cut yam, abraded yarns, loose or missing whipping, lines unraveling.	Material is badly worn or whipping is missing.

**Section III. OPERATION UNDER USUAL CONDITIONS**

**2-4. Fast Rope Operation.**

Refer to SOCOM Regulation 350-6.

**2-5. Personnel Harness Donning Instructions.**

The personnel harness (fig. 2-1) is designed to be worn by the user on patrol and to partially replace standard load-carrying equipment. As a result, the harness will be donned prior to departing on patrol using the following procedures:

- a. Determine the size of the assigned harness (small, medium, large) to ensure compatibility with individual size.
- b. Adjust the two harness web adjusters (3, fig. 2-1) to allow maximum extension of the harness straps (4). In like manner, adjust the adjustable snap hook (7) on each leg strap (8) to provide the maximum extended length possible on each leg strap.
- c. Insert the left loose end of the pistol belt through the left harness strap loop (5) formed directly above the left leg strap connector V-ring (6).
- d. Using the right loose end of the pistol belt, repeat the procedure in c. above on the right side of the harness.
- e. Position the two lift V-rings (1) toward the front of the harness adjacent to the equipment attaching rings (2).
- f. Place each arm into the respective shoulder strap and don the harness.
- g. Connect the pistol belt loose ends and position the belt near the midsection of the body.
- h. Adjust each side of the harness, as required, by grasping and pulling each harness strap loose end through the web adjuster. Adjustment should only be necessary if, prior to adjustment, the pistol belt is situated below the beltline.
- i. Extend the leg straps between the legs and connect each leg strap hook to the related connector V-ring below the pistol belt. Adjust each strap by pulling the strap loose end until the strap is snug.

**NOTE**

**When the harness is used on patrol, the leg straps may be disconnected, folded, and secured to a suitable point on the harness.**

**2-6. Assembling and Installing the Cargo and Personnel Lowering Anchoring Device.**

The cargo and personnel lowering anchoring device will be assembled for use and installed in the UH-1 aircraft as follows:

- a. Assembly.
  - (1) Install six connector snaps with buffers and three D-rings with buffers on the web loop. Ensure that the No. 2 and No. 5 connector snaps face toward the inside of the web loop. Further ensure that two D-rings are positioned between the No. 5 and No. 6 connector snaps.
  - (2) Insert 12 inches of the web loop loose end into the quick-fit adapter secured to the opposite end of the web loop length.

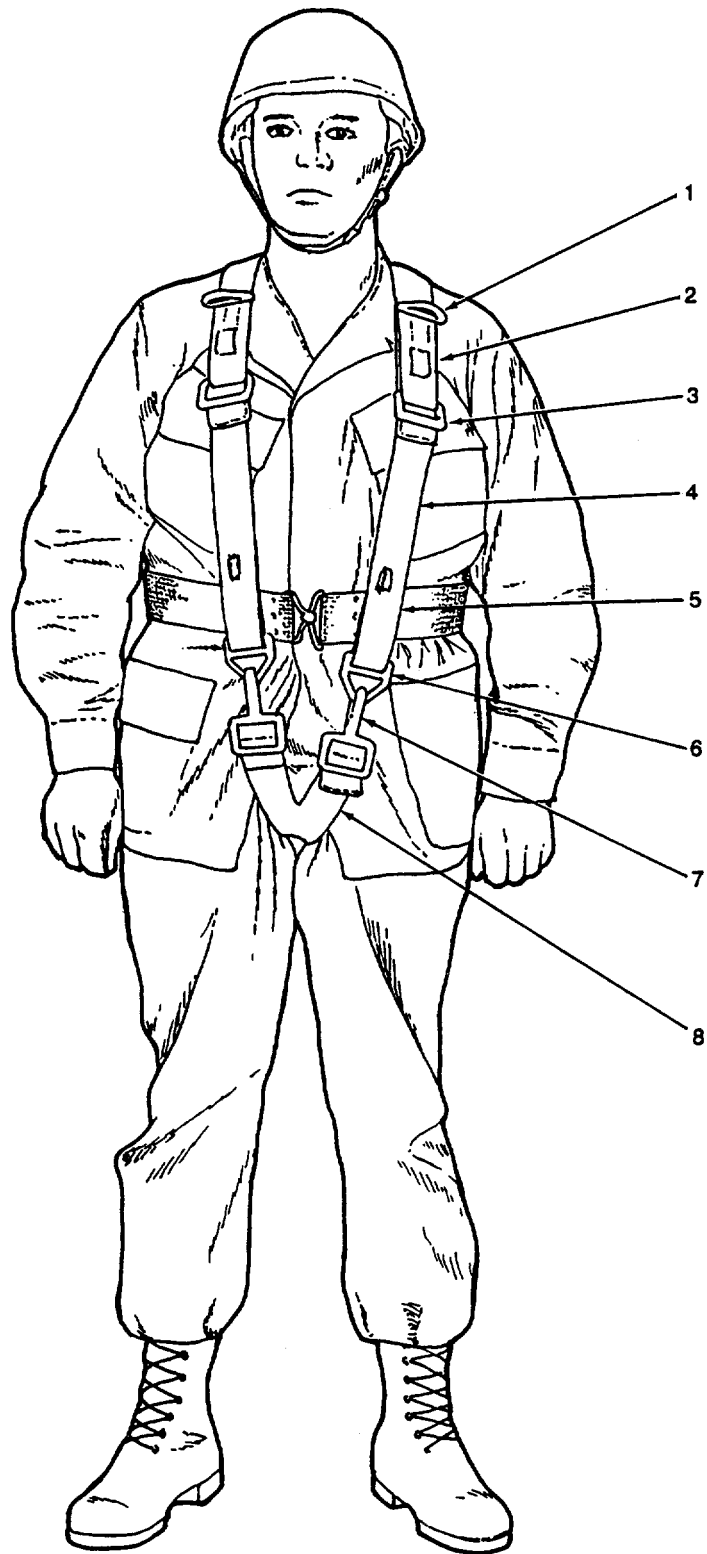

**LEGEND**

- 1. LIFT V-RING
- 2. EQUIPMENT ATTACHING RING
- 3. WEB ADJUSTER
- 4. HARNESS STRAP
- 5. HARNESS STRAP LOOP
- 6. CONNECTOR V-RING
- 7. ADJUSTABLE SNAP HOOK
- 8. LEG STRAP

**Figure 2-1. Extraction System Personnel Harness Donning Complete.**

**2-6. Assembling and Installing the Cargo and Personnel Lowering Anchoring Device - continued.**

b. Installation.

- (1) UH-1B, UH-1C, and UH-1M helicopters. The cargo and personnel lowering anchoring device shall be installed on the aircraft floor by connecting the six attached connector snaps of the web loop (2, fig. 2-2) to the applicable aircraft floor tiedown fittings (1, 6, 7, 8, 9, 15). On the UH-1C, the two center fittings (7, 15) are located at FS (fuselage station) 87.5 and BL (butt line) 10.0. When installing the web loop, ensure the quick-fit adapter (4) is positioned toward the front of the aircraft and the three D-rings (13) are located to the left side of the aircraft. Further ensure the four connector snaps which form the corners, two facing forward and two facing aft of the aircraft, are connected to the tiedown fittings on the outside of the web loop and the two center connector snaps are connected to the respective tiedown fittings on the inside of the web loop. The locking clip on each connector snap shall be in the safe position after attachment to a tiedown fitting. Pull the web loop loose end until all slack is removed from the loop webbing and the loop is tight. Fold and tape the web loop loose end (3). Using an anchoring device strap assembly (10) for each individual to be picked up, connect the strap adjustable quick-fit snap hook (11) to a D-ring on the web loop. With the web adjuster on the quick-fit snap hook, adjust the length of the strap to allow the attached strap D-ring to extend 10 inches over the left door sill. Upon completion of strap adjustment, insert the snap locking pin (12) into top of the snap guard and bend the extended pin end sufficiently to prevent inadvertent removal. Using pressure sensitive tape, apply tape to the left door sill and any other edge of the aircraft where the strap or extraction system components may pass.

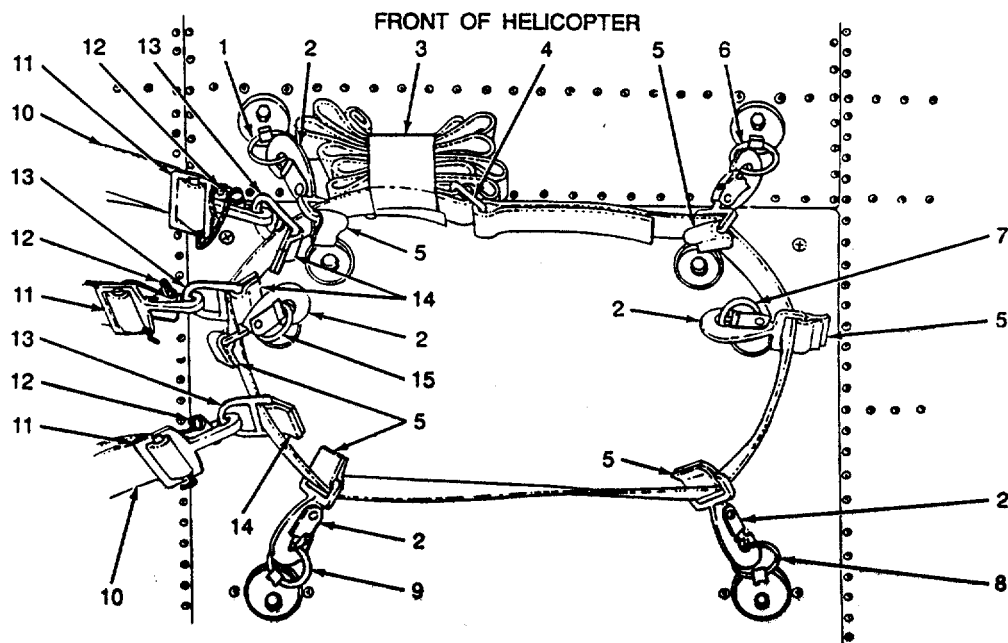

**Figure 2-2. Cargo and Personnel Lowering Anchoring Device Installed on UH-1B Aircraft Floor, Typical.**

- (2) UH-1D and UH-1H helicopters. Install the web loop on the aircraft floor as indicated in figure 2-3 and attach each strap assembly (3) as required.

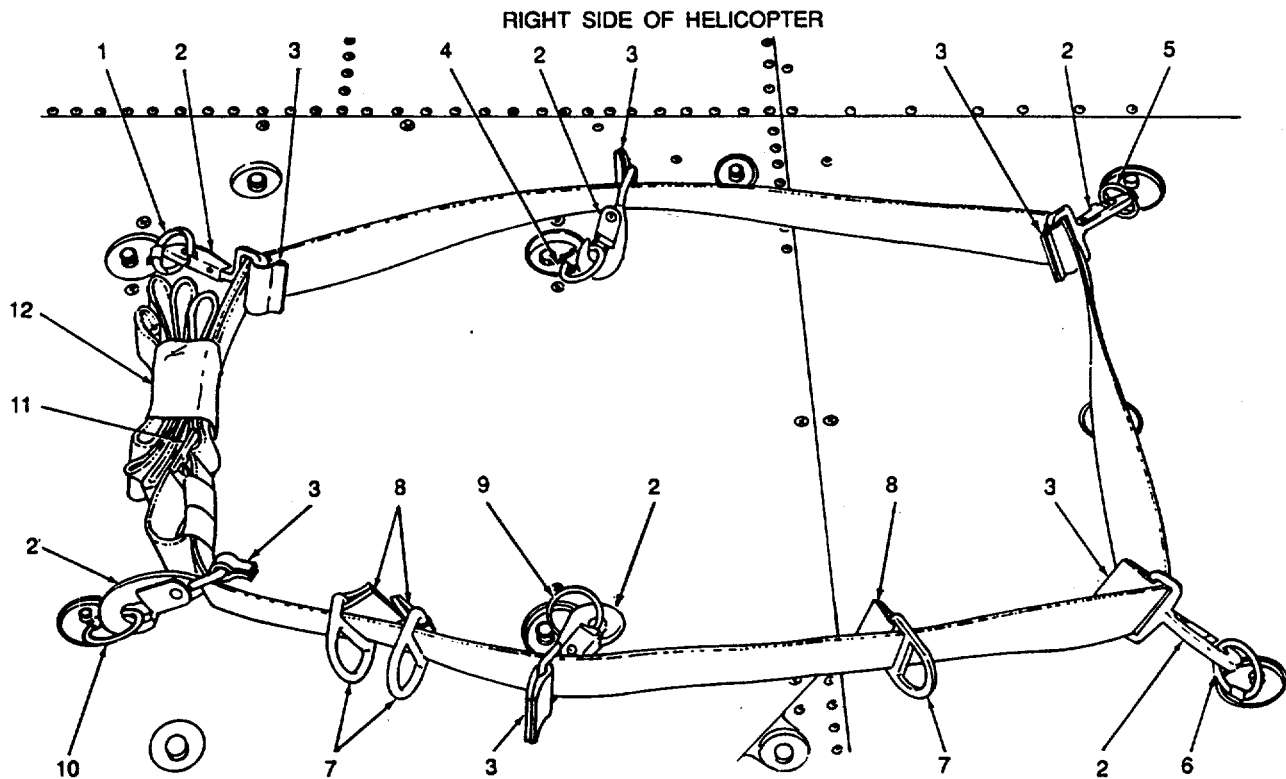

Figure 2-3. Web Loop Installed on UH-1D Aircraft Floor, Typical.

**2-7. Personnel Extraction Procedures.**

Upon reaching the vicinity in which personnel pickup is to be made, the following personnel extraction procedures shall be accomplished:

- a. Deploying the Extraction System.
  - (1) Prior to the helicopter attaining hover position, an aircraft crew member shall open the extraction system deployment bag by removing the two bag closing ties.
  - (2) Remove the suspension rope snap hook located just inside deployment bag end and attach the snap hook to a D-ring on the end of one anchoring device strap on the left side of the aircraft.



**2-7. Personnel Extraction Procedures - continued.****NOTE**

**A separate deployment bag must be deployed for each individual to be extracted and only one bag is to be connected to each strap D-ring.**

- (3) After the aircraft has attained hover position and upon the aircraft commander's command, the deployment bag(s) will be manually ejected from the aircraft.

b. Preparing for Extraction.

**WARNING**

**To prevent possible injury or discomfort, personnel to be extracted must ensure the harness leg straps are in place, connected, and drawn tight prior to connecting the bridle snap hooks to the personnel harness.**

- (1) After the deployment bag has deployed the full length of the suspension rope, the person to be extracted shall connect the two bridle snap hooks extending from the bridle to the two lift V-rings on the personnel harness.
- (2) If more than one individual is to be extracted, cut the safety rope retaining ties and remove the safety rope from the deployment bag.

**NOTE**

**Each deployment bag contains a safety rope. However, only one is required for use during multiple personnel extraction.**

- (3) Pass one end snap hook of the safety rope to one side of the personnel harness through the harness strap loop formed above the pistol belt to the outside of the loop and engage the snap on the rope.
- (4) When two persons are to be extracted, attach the opposite end of the safety rope using procedures in (3) above.
- (5) If three persons are to be extracted, repeat the procedures in (3) above for one individual, pass the safety rope free end through each of the two harness strap loops on the second person's harness, and connect the rope to the third person using procedures in (3) above. When properly rigged, the middle person should be free to move along the safety rope length between the two outboard personnel.
- (6) Upon ensuring that all preparations for extraction have been completed, signal the hovering helicopter by radio or hand to commence evacuation.

c. Hand Signals. In situations which preclude the use of a radio to signal the extracting helicopter, the following hand signals (fig. 2-4), as prescribed by FM 55-46, will be used by the personnel being extracted.

- (1) Move up. Extend the arms horizontally sideways beckoning upwards, with the palms of the hands turned up (A). Speed of arm movement shall indicate the desired rate of ascent.

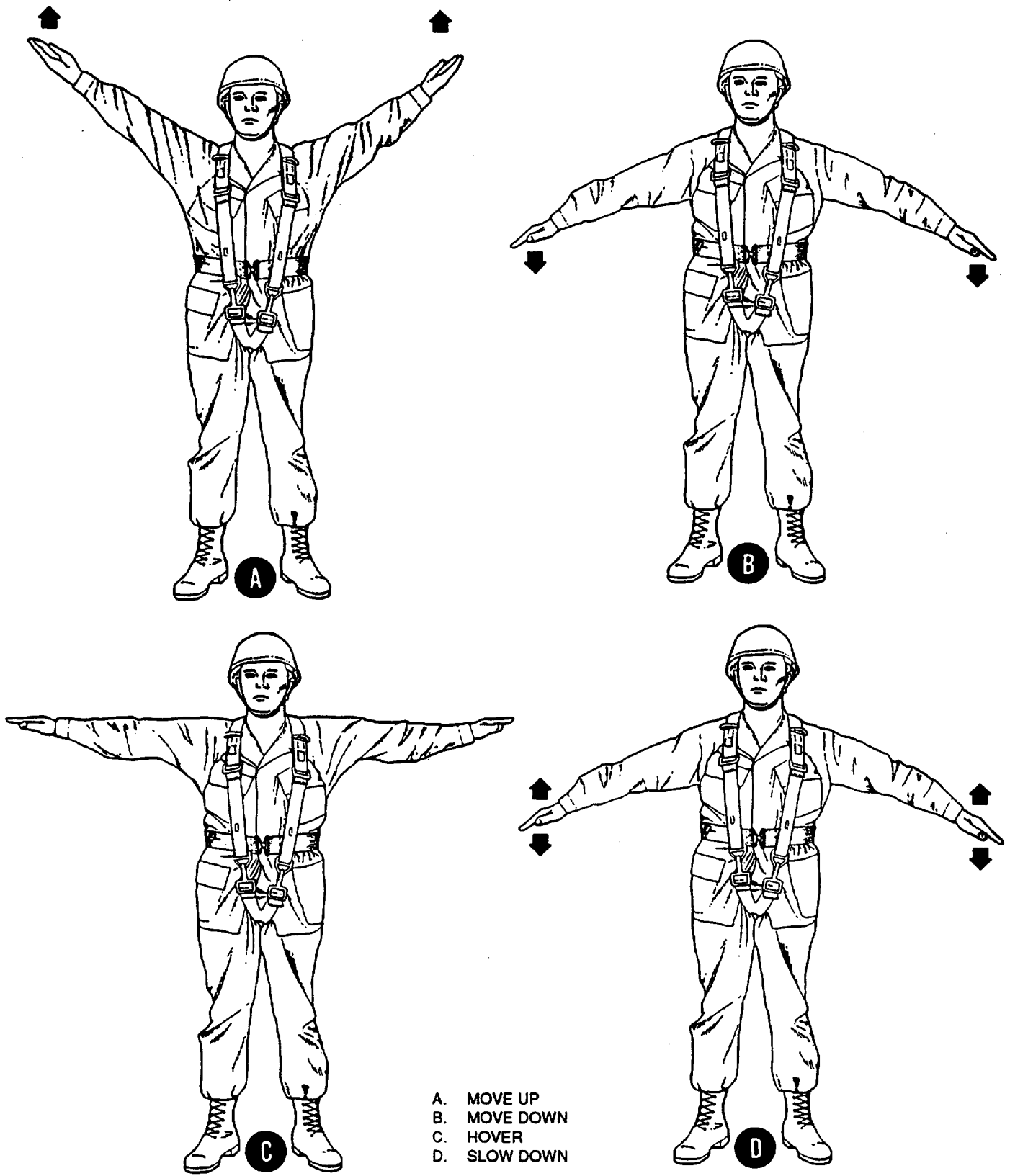

Figure 2-4. Hand Signals for Directing Helicopter Movement (Sheet 1 of 2)

2-7. Personnel Extraction Procedures - continued.

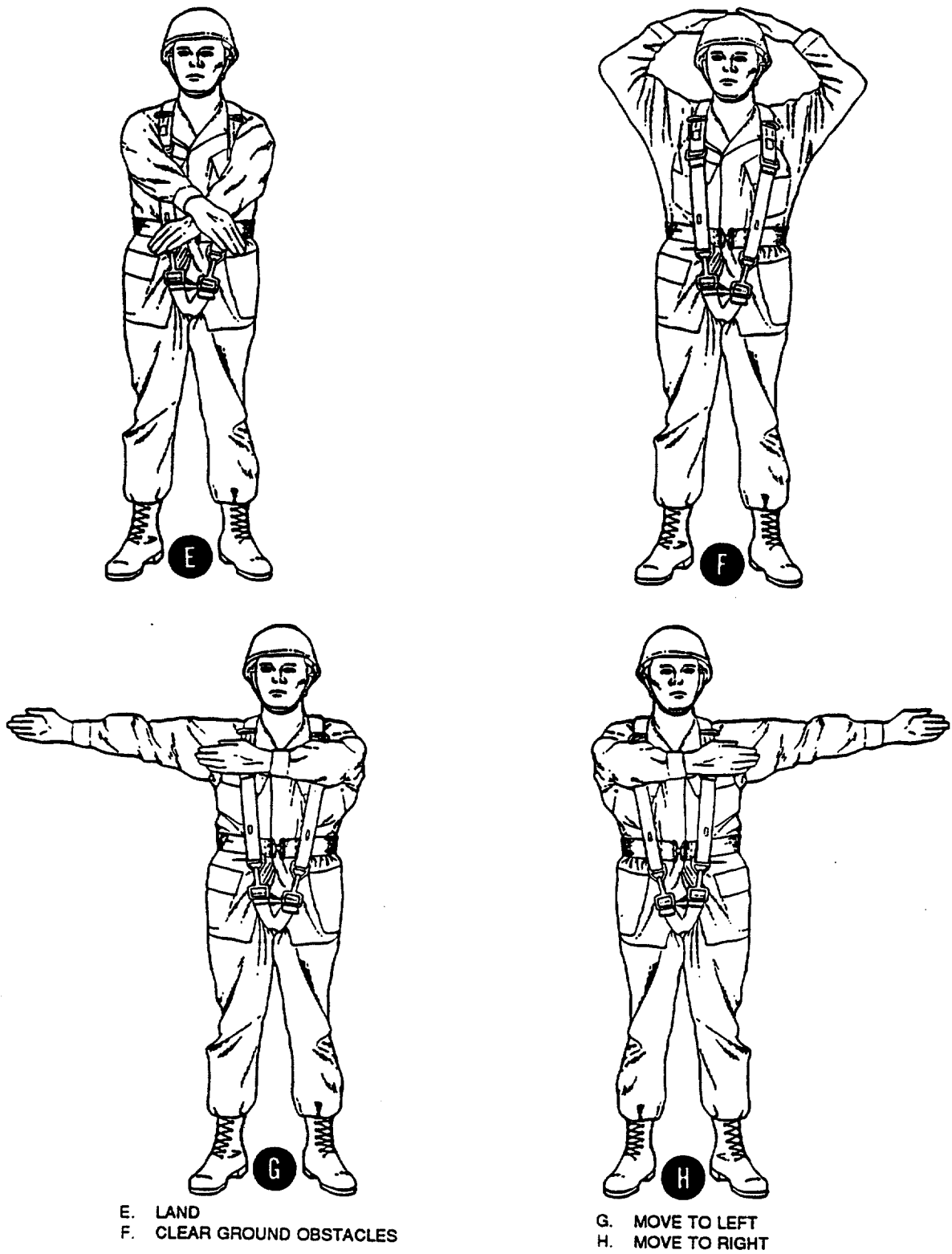

Figure 2-4. Hand Signals for Directing Helicopter Movement (Sheet 2 of 2)

- (2) Move down. Extend the arms horizontally sideways beckoning downwards, with the palms of the hands turned down (B). Speed of arm movement shall indicate the desired rate of descent.
- (3) Hover. Extend the arms horizontally sideways with palms of the hands turned downward (C).
- (4) Slowdown. Extend the arms down with palms of the hands turned down and move the arms slightly up and down (D).
- (5) Land. Cross the arms and extend the arms downward in front of the body (E).
- (6) Clear ground obstacles. Place both hands on top of the head with fingertips touching and elbows extended to the side (F).
- (7) Move to left. Extend the right arm sideways horizontally in the direction of desired movement and simultaneously swing the left arm in front of the body toward the desired direction of movement (G).
- (8) Move to right. Extend the left arm sideways horizontally in the direction of desired movement and simultaneously swing the right arm in front of the body toward the desired direction of movement (H).

**2-8. Aircraft Flight Speeds and Banking Maneuvers.**

**WARNING**

**To prevent injury or death, no flight, with extracted personnel suspended below the aircraft, shall exceed 80 KIAS.**

Normal extended helicopter flights, with extracted personnel suspended below the aircraft, shall be conducted using airspeeds up to 60 KIAS (knots indicated airspeed) with allowable banking turns of 40° or less. Under emergency conditions, extended flights may exceed 60 KIAS, but not more than 80 KIAS, with allowable banking turns of 30° or less.

**2-9. Fast Rope Operation.**

Refer to SOCOM Regulation 350-6.

**Section IV. OPERATION UNDER UNUSUAL CONDITIONS**

**2-10. Emergency Jettisoning Procedures.**

In the event an operational emergency occurs during extraction which may jeopardize the retrieving aircraft and crew, the deployed personnel STABO extraction system shall be jettisoned. Procedures for the aircraft crew-member to jettison the system are as follows:

- a. If the anchoring device strap assembly has sufficient slack unsnap the extraction system suspension rope and let it fall away from the aircraft.

**2-10. Emergency Jettisoning Procedures - continued.**

**WARNING**

To prevent injury or death when jettisoning, no attempt shall be made to cut a taut suspension rope near or by the extracted personnel, as a stretched rope that is cut could entangle in the rotor blades of the retrieval helicopter.

- b. Should the suspension rope be under tension, cut the strap assembly at point where the strap passes over the aircraft door sill.

**2-11. Fast Rope Operation.**

Refer to SOCOM Regulation 350-6.

## CHAPTER 3

## UNIT MAINTENANCE INSTRUCTIONS

**Section I. REPAIR PARTS; SPECIAL TOOLS; TEST, MEASUREMENT,  
AND DIAGNOSTIC EQUIPMENT (TMDE); AND SUPPORT EQUIPMENT****3-1. Common Tools and Equipment.**

For authorized common tools and equipment, refer to the Modified Table of Organization and Equipment (MTOE) applicable to your unit unless otherwise specified by the procuring activity.

**3-2. Special Tools, TMDE, and Support Equipment.**

There are no special tools or equipment required for this Technical Manual.

**3-3. Repair Parts.**

Repair parts are listed and illustrated in Appendix C of this manual.

**Section II. SERVICE UPON RECEIPT OF MATERIAL****3-4. Initial Receipt.**

When any component of the personnel STABO extraction system or cargo and personnel lowering anchoring device are received from a supply source, a technical/rigger type inspection will be performed. This inspection is to be conducted by the using unit prior to placing the items in service. After inspection, the concerned equipment may be either stored or placed into use for the insertion/extraction of personnel as may be required.

A technical/rigger type inspection is a complete and thorough inspection of an individual insertion/extraction item, including associated parts and components. The following criteria cites the specifics applicable to accomplishing a technical/rigger type inspection which will be performed by a qualified parachute rigger in accordance with AR 750-32.

**a. Inspection Intervals.**

- (1) Upon initial receipt of procured equipment issued to a using unit by a supply source.
- (2) Immediately before equipment is packed or rigged for use in insertion/extraction operations.
- (3) Before and after repairs or modifications are made.
- (4) At any other time as deemed necessary by the insertion/extraction equipment maintenance officer.

**3-4. Initial Receipt - continued.**

b. Inspection Function Requirement. Normally, a technical/rigger type inspection will be performed by airdrop equipment maintenance personnel at a packing, rigging, or repair activity. The inspection of initial receipt items will be performed as a separate function from packing or rigging operations. When the inspection is conducted at a packing or rigging activity, the item to be inspected will be placed in proper layout on packing table or suitable sized floor area. Should defect or damage be discovered at any point during the inspection, the inspection will be terminated and the applicable item will be processed and forwarded to a repair activity. The repair activity in turn, will conduct a technical/rigger type inspection that will be performed by only those parachute rigger personnel cited in AR 750-32. Any defect discovered during an organizational level repair activity inspection which exceeds the capability of that activity will require the affected item to be evacuated to a direct support maintenance function for further determination of economic repair and repair accomplishment, if applicable.

c. Technical/Rigger Type Inspection Procedures.

(1) Overall inspection. An overall inspection will be made to ascertain the following:

- (a) Assembly completeness. Ensure that the applicable assembly is complete and no components or parts are missing.
- (b) Operational adequacy. Check the item components and parts to ensure proper assembly which includes attachment and alignment, and that the assembled product functions in the prescribed manner. Further ensure that no stitch formation has been omitted, with particular attention directed to harnesses, web loops, bridles, strap assemblies, safety ropes, and rope assemblies.
- (c) Markings and paint. Inspect each assembly and associated components for faded, illegible, obliterated, or missing informational data, identification numbers, and warning marks. Also check for chipped, worn, or peeled paint, as applicable.
- (d) Foreign material and stains. Inspect each assembly and related components for the presence of dirt or similar type foreign material. Also check for evidence of mildew, moisture, oil, grease, pitch, resin, or contamination by salt water.

(2) Detailed inspection. In addition to the overall inspection performed in (1) above, a detailed inspection will be performed on the materials which constitute the assembly or component construction using the following criteria, as applicable:

- (a) Metal. Inspect for rust, corrosion, dents, bends, breaks, burrs, rough spots, sharp edges, wear, deterioration; damaged, loose, or missing nuts, bolts, screws, safety pins, or rivets; improper swaging or welding; loss of spring tension.
- (b) Plastic and wood. Inspect for bends, breaks, dents, holes, rough spots, sharp edges, and wear.
- (c) Cloth. Inspect for breaks, burns, cuts, frays, holes, rips, snags, tears; loose, missing, or broken stitching or tacking; weak spots, wear, or deterioration.
- (d) Fabric tape, webbing, and cordage. Inspect for breaks, burns, cuts, frays, holes, snags, tears, incorrect weaving, and sharp edges formed from searing; loose, missing, or broken stitching, tacking, whipping, and weaving; weak spots, wear, and deterioration.

- (e) Pressure-sensitive (adhesive) tape. Inspect for burns, holes, cuts, tears, weak spots; looseness and deterioration.
- (f) Rubber and elastic. Inspect for burns, cuts, holes, tears, weak spots; loss of elasticity and deterioration.
- (g) Felt. Inspect for cuts, tears, burns, breaks, holes, and thin spots.
- (h) Leather. Inspect for burns, cuts, holes, tears, loose, missing, or broken stitching; thin spots and deterioration.

### **3-5. After Use Receipt.**

After being used for personnel extraction, all components of the personnel STABO extraction system and the cargo and personnel lowering anchoring device shall be inspected for damage or defects. A compressed air hose may be used to remove foreign material from inaccessible locations, as required.

Insertion/extraction equipment will be inspected after each use for dampness, dirt, or other foreign material. Subsequent cleaning and drying of the equipment may be required to prevent a possible malfunction or deterioration of the item(s). The cleaning and drying of insertion/extraction equipment will be accomplished as follows:

#### **CAUTION**

**If, during the cleaning of an insertion/extraction item there exists a possibility that a substance to be removed contains acid, an acidity test will be performed. Should the substance be acid-free, the item will be evacuated to a direct support maintenance activity for determination as to the nature of the substance and item disposition. If a substance cannot be identified or if normal repair procedures will not eliminate all traces of chemical damage, the applicable item will be condemned.**

a. Cleaning. The practice of cleaning insertion/extraction items should be held to a minimum and performed only when it is necessary to eliminate a malfunction potential or the possibility of material deterioration. The method of cleaning to be used must be compatible with the type of material to be cleaned and the nature of the substance to be removed. In addition, the cleaning process should be limited to the soiled area only. The cleaning of insertion/extraction equipment will be performed using the following procedures, as applicable:

- (1) Shaking and brushing. Most insertion/extraction equipment assemblies and associated components should be cleaned by shaking or gently brushing with a dry soft-bristle brush. A dry stiff-bristle brush may be used on insertion/extraction items constructed of canvas, metal, or wood.
- (2) Spot cleaning. A soiled area on a fabric insertion/extraction item which cannot be cleaned by shaking or brushing will be spot-cleaned as follows.



**3-5. After Use Receipt - continued.****WARNING**

Due to flammable properties and nylon-damaging substances, cleaning solvents other than tetrachloroethylene will not be used in the spotcleaning of insertion/extraction equipment. Tetrachloroethylene will only be used in areas where substantial ventilation is available. Repeated or prolonged inhalation of the solvent vapors can be detrimental to human health. In addition, avoid prolonged or repeated contact of the solvent fluid with areas of the skin. Tetrachloroethylene must not be taken internally.

- (a) Cotton item. Spot-clean a cotton item by rubbing the soiled area with a clean cloth dampened with tetrachloroethylene. Once the foreign substance has been removed, rinse the cleaned area by repeating the rubbing process with clean portion of the cloth which has been dampened with the cleaning solvent. Do not wring out the rinsed area if an undue amount of cleaning solvent is applied. Allow the applicable item to dry thoroughly.
- (b) Nylon and rayon items. A soiled nylon or rayon item, except a personnel harness soiled by airsickness, may be spot-cleaned using the procedures in (a) above. However, the tetrachloroethylene may be substituted by a solution composed of one-half cup of hand dishwashing detergent (liquid or powdered) dissolved in one gallon of warm water. A soiled area cleaned with the soap and water solution will be rinsed with fresh, clean water and allowed to dry thoroughly. Do not attempt to wring out the material which has been cleaned and rinsed.

**CAUTION**

**When cleaning a personnel harness soiled by airsickness, ensure the water used to wash a harness is only warm and not hot.**

- (c) Personnel harness. A personnel harness which has been soiled by airsickness will be cleaned by immersing the harness in a soap and warm water solution similar to that prescribed in (b) above. A stiff-bristle brush may be used to remove stubborn foreign deposits by lightly brushing the affected area(s) during the soaping process. Rinse the cleaned area(s) in fresh, clean water until the rinse water remains clear, indicating complete removal of soap. Allow the harness to dry thoroughly without being exposed to direct sunlight or heat which exceed the specifics of paragraph (f) below.
- (d) Plastic and wood items. Spot cleaning of a plastic or wood item will be accomplished by using procedures in (a) or (b) above, as required. Imperfections on plastic items may be removed by buffing with crocus cloth. Similar type defects on wood items can be disposed of through use of a suitable grade sandpaper. When applicable, ensure that the adjacent fabric materials are not damaged when buffing or sanding.

- (e) Metal items. Burrs, rough spots, rust, or corrosion on metal items that cannot be eliminated by brushing or spot cleaning, using procedures in (1) and (2) above, may be removed by filing with a metal file or by buffing and polishing with crocus cloth or steel wool. When applicable, ensure that the adjacent fabric materials are not damaged when filing, buffing, or polishing. When the metal item has been properly smoothed, remove all oils and filings by brushing and dipping in tetrachloroethylene. When the tetrachloroethylene has dried, spray the metal item with a dry film lubricant and allow to air dry for 24 hours and put hardware back into service. Shield adjacent fabric material when spraying dry film lubricant to prevent saturation. Small amounts of lubricant will not damage fabric, but may cause discoloration and make fabric appear soiled.
- (f) Drying. Insertion/extraction equipment that is wet or damp will be suspended or elevated in a well ventilated room or in a heated drying room. Item drying time may be reduced through the use of electric circulating fans. When heat is used, the heat temperature will not be in excess of 160°F with preferred temperature at 140°F until the item is dry. Fabric or wooden items will not be dried in direct sunlight or by laying an item out on the ground, except in an emergency.

### **3-6. Service Life.**

- a. The personnel STABO extraction system does not have a prescribed service life. The length of time the system components may remain serviceable shall depend on the results of required inspections performed.
- b. The maximum service life of the web loop and each of the strap assemblies shall be computed as 10 years from the date of manufacture which is stenciled on the web loop and each strap.

## **Section III. PACKING PROCEDURES**

### **13-7. General.**

Packing of the personnel STABO extraction system applies to the layout and stowing of the suspension rope, bridle, and safety rope, along with closing of the deployment bag. During packing, the deployment bag shall be secured to the suspension rope at two points to prevent loss of the bag when the system is used.

### **3-8. Proper Layout.**

To place the STABO extraction system in proper layout, perform the following:

- a. Position the deployment bag on a flat surface with the suspension rope stow loops facing up.
- b. Remove all tangles from the suspension rope, if applicable, and coil the rope at a point near the bag opposite the weighted end of the bag.

### **NOTE**

**The weighted portion of the deployment bag is considered the bag bottom end.**

**3-9. Packing Details.**

- a. Beginning with the second stow loop from the bag bottom, attach a suspension line retainer band to each of the suspension rope stow loops located on both sides of the deployment bag.
- b. Cut two 24-in. lengths of type I, 1/4-in. wide cotton webbing or two 12-in. lengths of either type II or type III nylon cord, with core threads removed, for use as suspension rope retainer ties. The retainer ties provide a means for the deployment bag to remain connected to the suspension rope during system deployment.
- c. Secure one retainer tie length cut in b. above, using one turn double, type I, 1/4-in. wide cotton webbing or one turn single, types II or III nylon cord, with core threads removed, to the suspension rope retainer web loop located at the bottom center of the bag body with a square knot.
- d. Attach the second retainer tie length to the retainer web loop, located at the top center of the bag body using procedures in c. above (fig. 3-1).

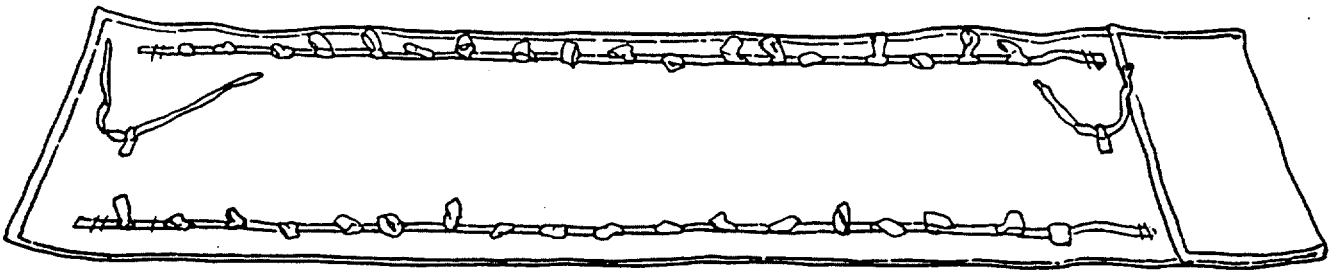

**Figure 3-1. Suspension Rope Retainer Ties Attached to Retainer Web Loops, Typical.**

- e. Extend one end of the suspension rope along the center of the bag toward the bag bottom end and position the suspension rope bottom snap hook attaching loop over the bottom retainer web loop.
- f. Using the retainer tie installed in c. above, secure the snap hook attaching loop to the retainer web loop by passing a retainer tie loose end through the attaching loop and join both tie loose ends with a surgeon's and locking knot. Trim the tie running ends to 1/2 in.
- g. Center the extended suspension rope length over the top retainer web loop and secure the rope length to the web loop by making a surgeon's and locking knot with the retainer tie loose ends (fig. 3-2). Trim the tie ends to 1/2 in.

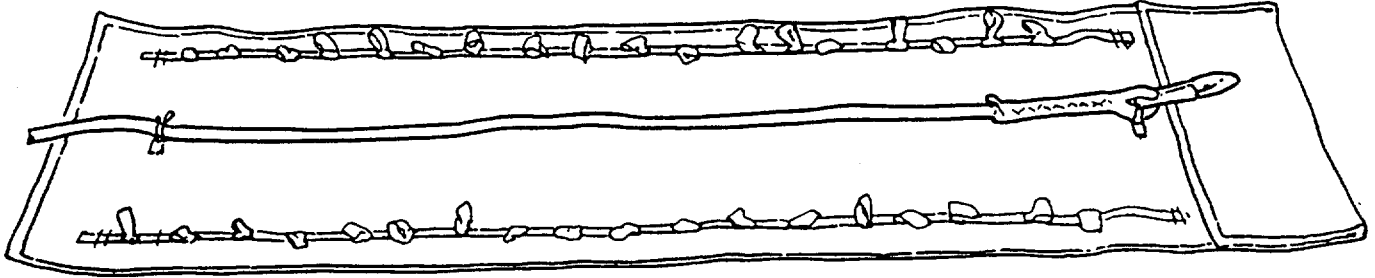

**Figure 3-2. Suspension Rope Retainer Ties Completed.**

- h. Position the safety rope on the bottom end of the deployment bag and connect each of the two safety rope snap hooks to the first suspension rope stow loops located on both sides of the bag body, adjacent to the bag bottom end (fig. 3-3).

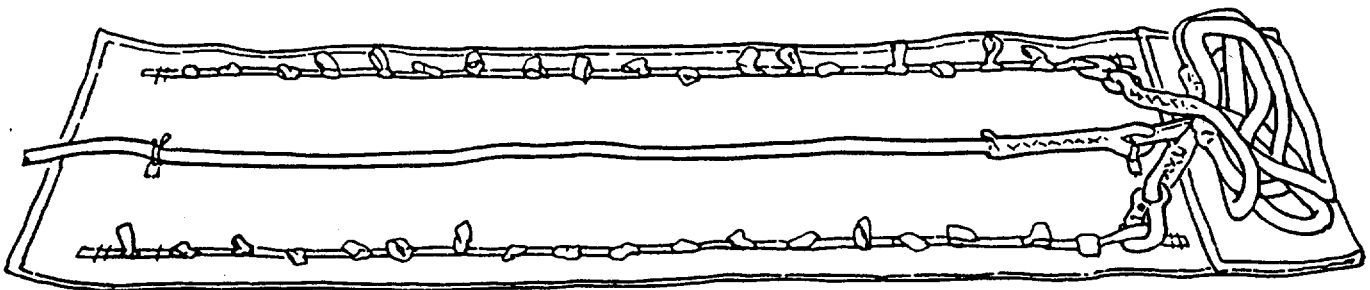

**Figure 3-3. Attaching the Safety Rope to Deployment Bag.**

- i. Stow the safety rope by accordion folding the rope over the first two suspension rope stow loops to a point 1/2 in. from each edge of the deployment bag. Secure both ends of the folded rope to the stow loops with one turn single, type 1, 1/4-in. wide cotton webbing, using a surgeon's and locking knot (fig. 3-4).

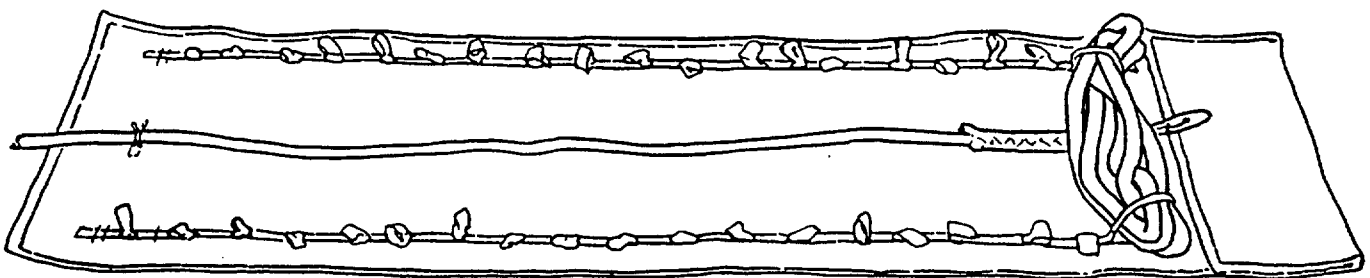

**Figure 3-4. Stowing of Safety Rope Completed.**

**3-9. Packing Details - continued.**

- j. Extend the suspension rope running end toward the second stow loop located at the bottom left of the bag body. To form the rope stows, make three accordion folds in the rope across the width of the bag to a point 1/2 in. from each edge of the bag and end the last fold on the bag bottom right. Secure each formed stow with the retainer bands attached to the second stow loops (fig. 3-5).

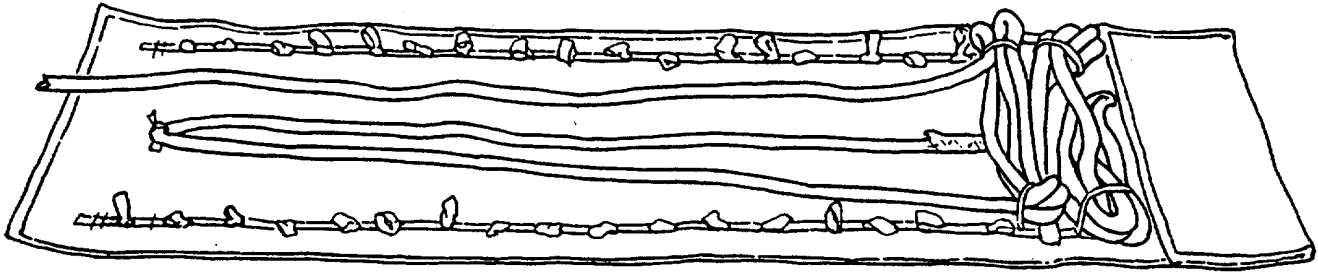

**Figure 3-5. First Stows of Suspension Rope Completed.**

- k. Using procedure in j. above, continue stowing the suspension rope length to a point 12 in. from the top snap hook on the rope end. Connect the snap hook to the top retainer web loop (fig. 3-6).
- l. At the bag bottom end, connect the suspension rope bottom snap hook to the D-ring on the top of the bridle and S-fold the bridle on the bag bottom in a manner which will preclude the bridle from extending beyond the sides of the bag (fig. 3-6).

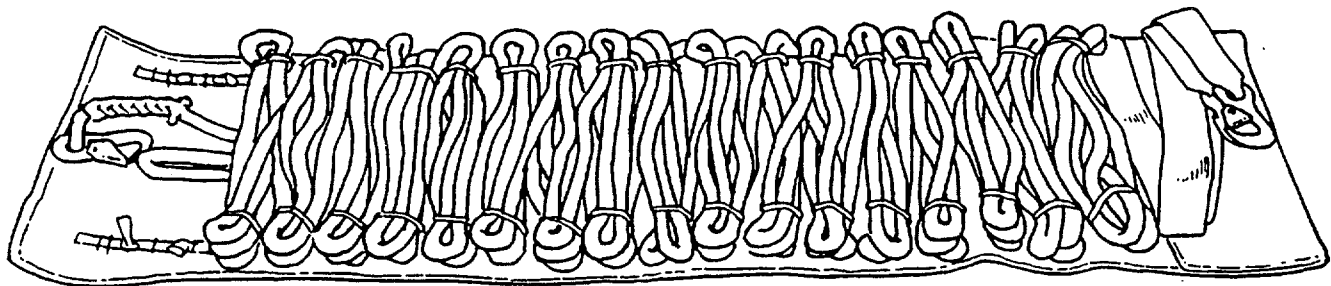

**Figure 3-6. Suspension Rope, Safety Rope, and Bridle Storage Completed.**

- m. Beginning at the bottom end of the bag, close the bag by rolling the bag toward the bag top. Secure each end of the closed bag with one turn single, type 1, 1/4-in. wide cotton webbing, using a surgeon's and locking knot. Trim the tie ends to 2 in. (fig. 3-7).

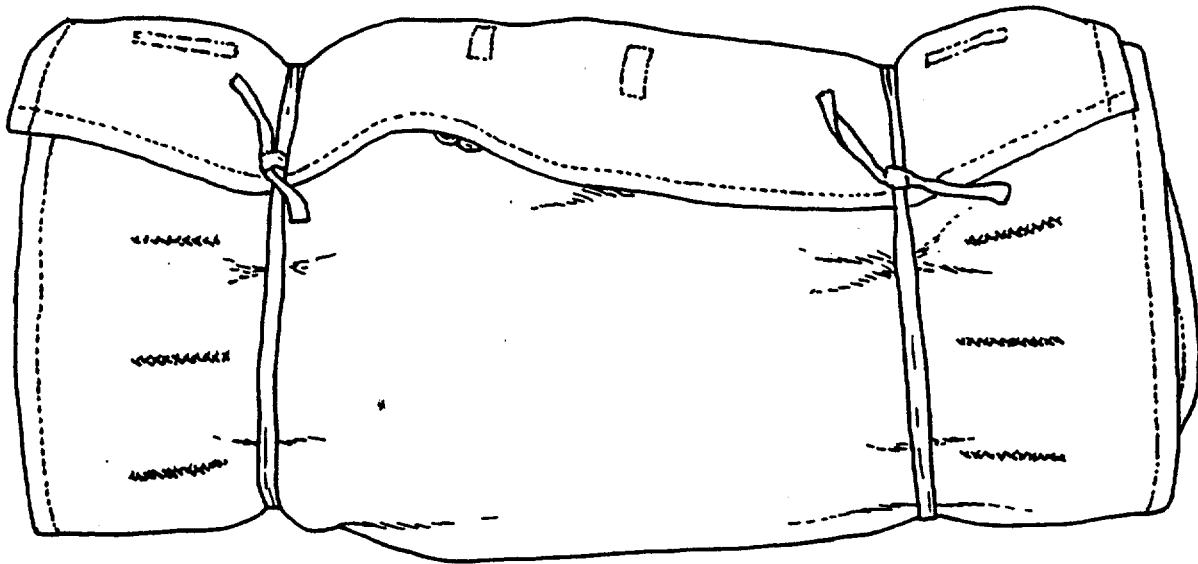

Figure 3-7. Deployment Bag Closed and Secured.

#### Section IV. UNIT PREVENTIVE MAINTENANCE CHECKS AND SERVICES (PMCS)

##### 3-10. Introduction.

To ensure that all components of the Personnel Insertion/Extraction System are ready for use at all times, they must be inspected at prescribed intervals to determine their serviceability. The two types of inspections normally performed are Routine and Technical/Rigger which are defined in paragraph 3-11. All defects discovered during inspection will be recorded on forms in accordance with DA PAM 738-750 and DA PAM 738-751 at the earliest possible opportunity. If during an inspection any component, except the deployment bag, is found to be defective or the serviceability of the item is doubtful, the component concerned shall be replaced.

##### 3-11. Unit Preventive Maintenance Checks and Services Procedures.

- a. This paragraph contains a tabulated listing (table 3-1) of preventive maintenance checks and services which will be performed by qualified rigger personnel (MOS 43E) at indicated intervals.
- b. Routine Inspection. The routine type inspection will be performed by the user before and after use (table 3-1).
- c. Technical/Rigger Type Inspection. The technical/rigger type inspection will be performed by a qualified rigger before packing, and before and after repairs.
- d. Unit level PMCS is contained in table 3-1. The numbers in the Item No. column show the order in which the check or service should be done. These numbers should be used when recording deficiencies and shortcomings on DA Form 2404, Equipment Inspection and Maintenance Worksheet. The dot (-) in the interval column indicates when a check or service should be done, Before (B) or After (A) operations inspections.

**3-11. Unit Preventive Maintenance Checks and Services Procedures - continued.**

**Table 3-1. Unit Preventive Maintenance Checks and Services (PMCS)**

Item No.	Interval		Item to be Inspected	Procedures
	(B)	(A)		
1	●	●	Deployment Bag	Inspect for wear and tears. Refer to para. 3-5.
2	●	●	Personnel Harness	Visually inspect for cuts, snags, broken stitching; replace if damaged beyond repair.
3	●	●	Cargo and Personnel Lowering and Anchoring Device	Visually inspect for cuts, snags, broken stitching; replace if damaged beyond repair.
4	●	●	Suspension Rope	Visually inspect for cuts, abrasions, melting, or fuzzing
5	●	●	Safety Rope	Visually inspect for cuts, abrasions, melting, or fuzzing.
6	●	●	Fast Rope Insertion/ Extraction System Components	Visually inspect for burns, cut yarn, abraded yarns, loose or missing whipping, lines unraveling.

Before (B)    After (A)

Section V. MAINTENANCE PROCEDURES

**3-12. Personnel Stabilized Body Extraction System.**

---

This task covers:      a. Inspect                      b. Service                      c. Repair                      d. Replace

---

**INITIAL SETUP**

Tools

See appx B

Personnel Required

Parachute Rigger MOS 43E

Materials/Parts

See appx D

Equipment Conditions

Unpacked. Laid out on table.

---

**NOTE**

**There are seven separate items in this system. Each item has Initial Setup requirements and Maintenance Procedures presented in separate paragraphs (3-13 through 3-23 below).**



**3-13. Cargo and Personnel Anchoring Device (Web Loop).**

This task covers:      a. Inspect                      b. Replace

**INITIAL SETUP**

<u>Tools</u>	<u>Materials/Parts</u>
None	None

**a. Inspect**

Inspect web loop (fig. 3-8) for rubs, cuts, tears, broken or missing stitching, missing or loose hardware, and burrs.

**b. Replace**

Replace an unserviceable/unrepairable cargo and personnel web loop with one from stock.

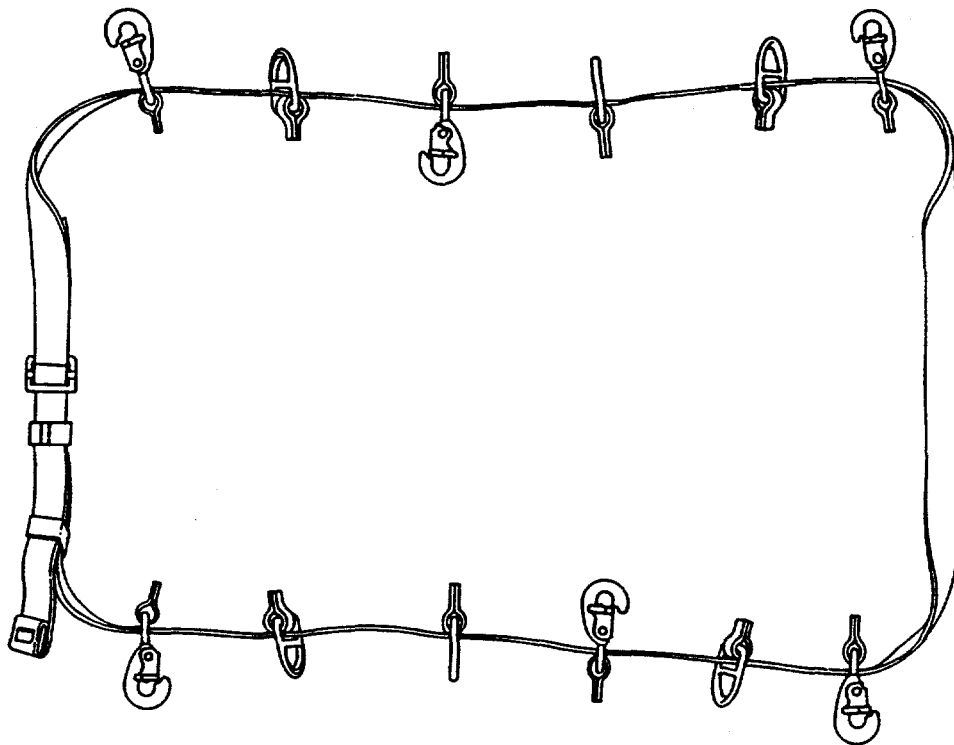

**Figure 3-8.      Web Loop, Typical.**

**3-14. Strap Assembly.**

---

This task covers:      a. Inspect                      b. Repair                      c. Replace

---

**INITIAL SETUP****Tools**

Shears (item 6, appx B)

**Equipment Conditions**

Unpacked. Clean.

**Materials/Parts**

Cord, Nylon (item 2, appx D)

**a. Inspect**

- (1) Inspect strap assembly (1, fig. 3-9) snap hook (2) operation.
- (2) Inspect locking pin retaining cord (3).

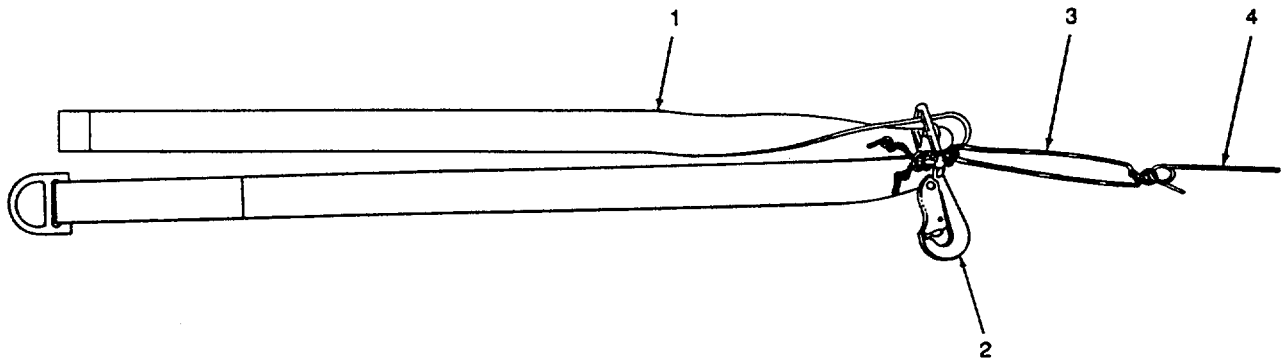

**Figure 3-9. Strap Assembly, Typical.**

**b. Repair**

- (1) Cut a 5 in. length of 0.080-in. diameter corrosion resistant steel wire and form a 3 1/8 in. locking pin (4).
- (2) Remove core cords from a 20 in. length of type II nylon cord. Tie an overhand knot in each end and sear ends. Fold cord in half and attach to locking pin with a girth hitch.
- (3) Tie an overhand knot in the cord no closer than 5 in. from the locking pin. Run one end of the cord through the adjuster of the snap hook and secure with a surgeon's and locking knot.

**c. Replace**

Replace an unserviceable/unrepairable strap assembly with one from stock.

**3-15. Suspension Rope.**

This task covers:      a. Inspect                      b. Replace

**INITIAL SETUP**

Tools

None

Equipment Conditions

Clean, dry, and free of tangles.

Materials/Parts

None

**a. Inspect**

Check to see that the rope (fig. 3-10) is not frayed, abraded, melted, cut, or otherwise damaged. Melting damage can be detected by a rough feel of the rope surface. Discard the rope for personnel use when it shows signs of fraying or melting damage. Discard the rope for cargo use when SEVERE fraying or melting damage is noted. Insure the rope is dry and is 147-feet long.

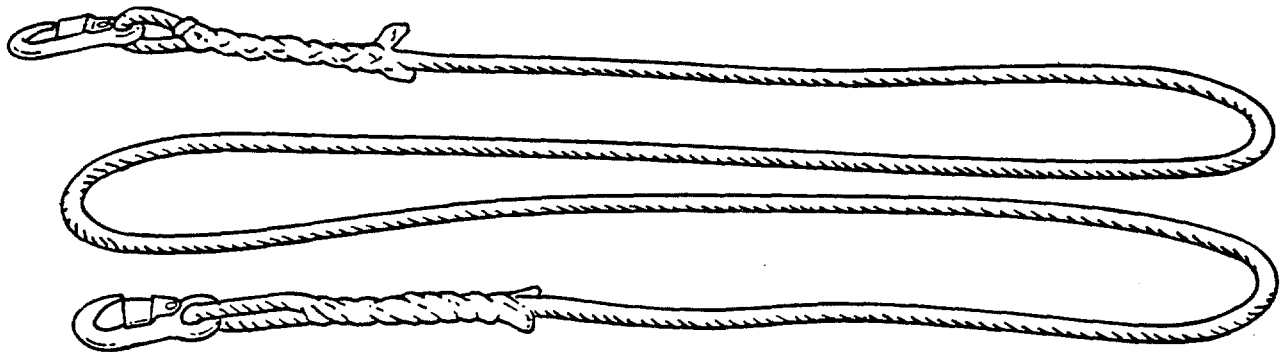

**Figure 3-10. Suspension Rope.**

**b. Replace**

**WARNING**

**When in doubt about the serviceability of suspension rope, replace it.**

Replace an unserviceable suspension rope with one from stock.

**3-16. Deployment Bag.**

---

This task covers:      a. Inspect                      b. Repair                      c. Replace

---

**INITIAL SETUP**Tools

Shears (item 6, appx B)  
 Needle (item 4, appx B)  
 Sewing Machine, Medium Duty (item 9, appx B)  
 Sewing Machine, Darning (item 8, appx B)

Equipment Conditions

Equipment removed from deployment bag.

Materials/Parts

Thread, Size E (items 8 and 9, appx D)  
 Webbing, Nylon (item 1, appx D)

---

**a. Inspect**

Inspect for tears, cuts, and broken or missing stitching.

**b. Repair**

- (1) Restitching. Restitch deployment bag (fig. 3-11) using a medium duty sewing machine and size E nylon thread of contrasting color. Stitch over original pattern, 7 to 11 stitches per inch. Lock each row of stitches 1/2-inch at each end. Refer to paragraph 3-27.

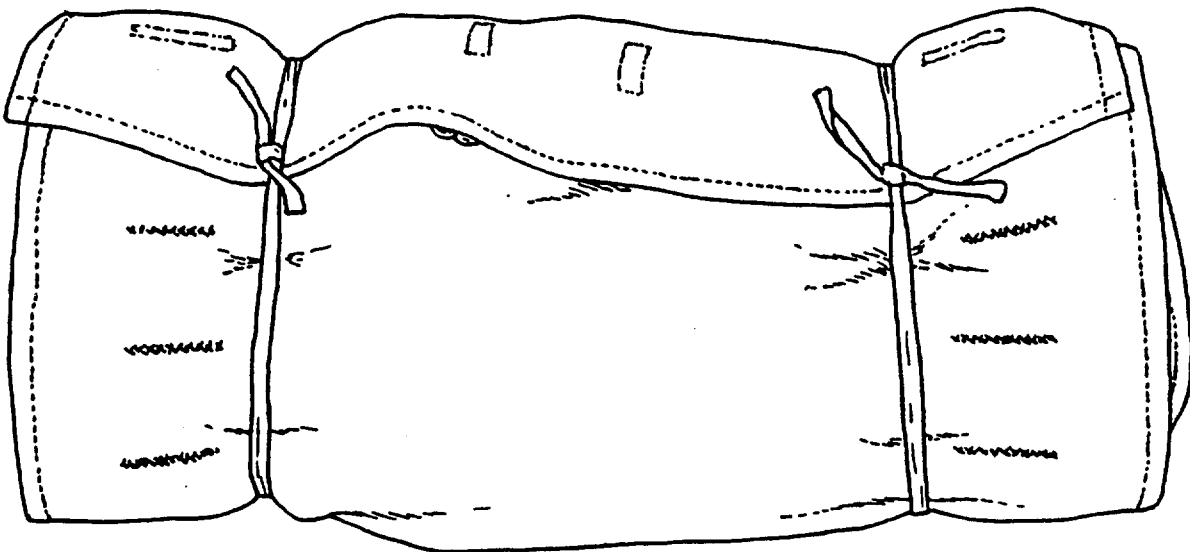

Figure 3-11. Deployment Bag.

**3-16. Deployment Bag - continued.**

- (2) Darning. Dam deployment bag using a darning machine or hand darning and size E nylon thread of contrasting color. Maximum size damaged area which can be repaired by darning shall not exceed 1/2 inch.

**c. Replace**

- (1) Remove rope from deployment bag.
- (2) Procure a new deployment bag from stock.
- (3) Stow rope in deployment bag.

**3-17. Safety Rope.**

This task covers:      a. Inspect                      b. Replace

**INITIAL SETUP**

Tools

None

Materials/Parts

None

Equipment Conditions

Unpacked. Lowering device with defects recorded and clean.

**a. Inspect**

- (1) Inspect safety rope (fig. 3-12) for broken loops (2), frayed, worn, or cut safety rope.
- (2) Inspect for bent, broken, or rusted snap hooks (1).

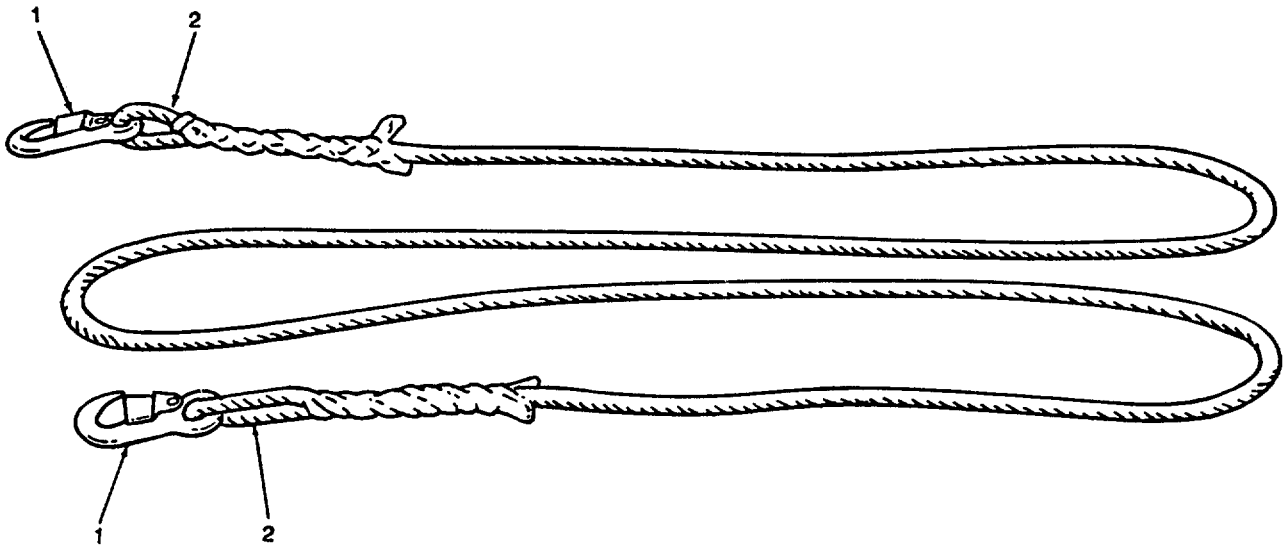

**Figure 3-12. Safety Rope.**

**b. Replace**

Replace an unserviceable safety rope with one from stock.

**3-18. Bridle.**

---

This task covers:      a. Inspect                      b. Replace

---

**INITIAL SETUP**Tools

None

Equipment Conditions

Equipment removed from deployment bag.

Materials/Parts

None

---

**a. Inspect**

- (1) Inspect bridle (fig. 3-13) for cuts, abrasions, burrs on hardware, and foreign material.
- (2) Inspect for broken, loose, or missing stitching.

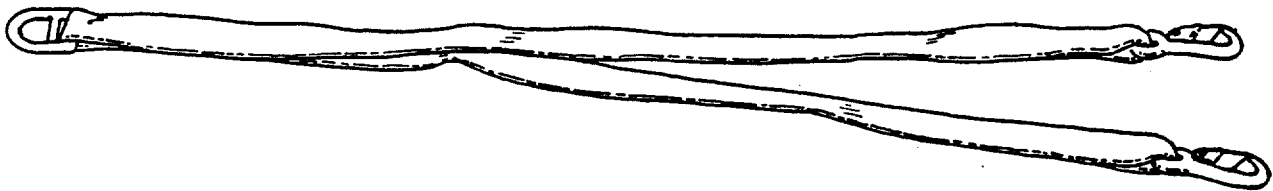

**Figure 3-13. Bridle.**

**b. Replace**

Replace an unserviceable bridle with one from stock.

**3-19. Personnel Harness.**

---

This task covers:      a. Inspect                      b. Replace

---

**INITIAL SETUP**Tools

None

Equipment Conditions

Laid out on table.

Materials/Parts

None

**a. Inspect**

Inspect personnel harness (fig. 3-14) for rubs, cuts, tears, broken or missing stitching, missing or loose hardware, and burrs.

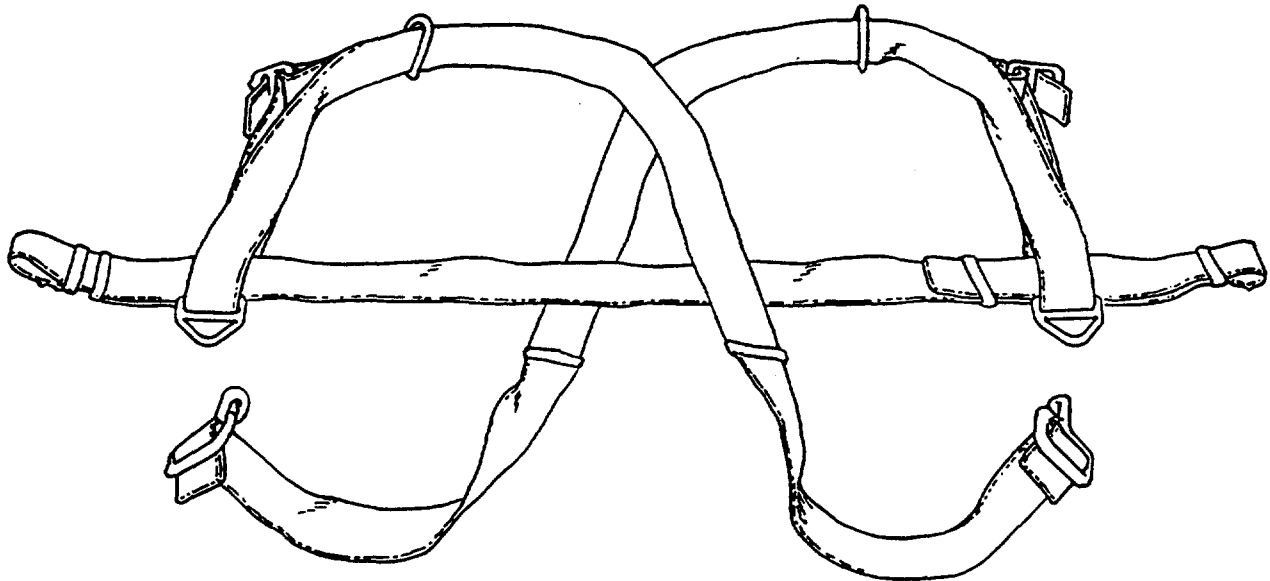

Figure 3-14. Personnel Harness.

**b. Replace**

Replace unserviceable or unrepairable personnel harness with one from stock.



**3-20. Fast Rope Insertion/Extraction System.**

This task covers:      a. Inspect                      b. Replace

**INITIAL SETUP**

Tools

Artificial or Natural Hair Brush

Equipment Conditions

Unpacked.

Materials/Parts

None

**NOTE**

The fast rope insertion/extraction system (fig. 3-15) is made up of three separate items which will be covered separately by maintenance procedures. They are (1) Fast Rope, Bridle, and Personnel Harness.

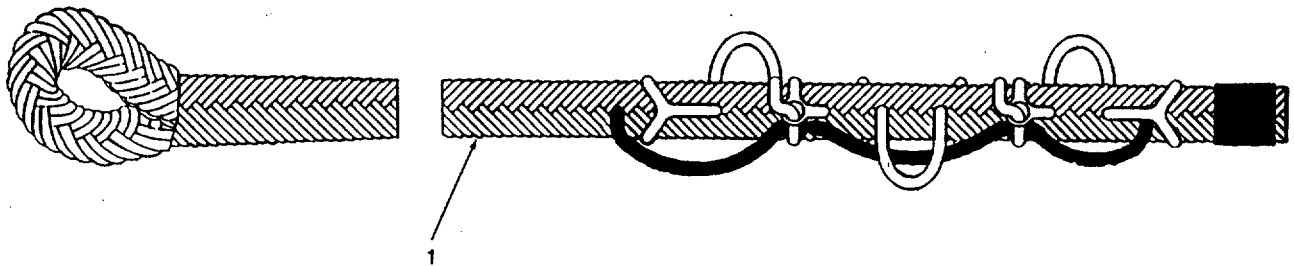

**Figure 3-15. Fast Rope Insertion/Extraction System.**

**3-21. Fast Rope.**

---

This task covers:      a. Inspect                      b. Service                      c. Replace

---

**INITIAL SETUP**

Tools

Artificial or Natural Hair Brush

Equipment Conditions

Unpacked. Laid out on work table.

Materials/Parts

None

---

**a. Inspect**

- (1) Inspect fast rope for cleanliness.
- (2) Inspect for bums, cut yam, loose or missing whipping, and lines unraveling.

**b. Service**

Clean the fast rope with an artificial or natural hair brush.

**NOTE**

**Do not use cleaning fluid or water.**

**c. Replace**

Replace unserviceable fast rope with one from stock.

**3-22. Bridle.**

---

This task covers:      a. Inspect                      b. Replace

---

**INITIAL SETUP**Tools

None

Equipment Conditions

Unpacked. Laid out on work table.

Materials/Parts

None

---

**a. Inspect**

- (1) Inspect for broken or missing stitching, frayed, worn, or cut webbing (Fig. 3-13).
- (2) Inspect for bums, cut or abraded yams, loose or missing whipping, and lines unraveling.

**b. Replace**

Replace an unusable/unserviceable bridle with one from stock.

**3-23. Personnel Harness.**

---

This task covers:      a. Inspect                      b. Replace

---

**INITIAL SETUP**Tools

None

Equipment Conditions

Unpacked. Laid out on work table.

Materials/Parts

None

---

**a. Inspect**

- (1) Inspect for missing stitching, frayed, worn, or cut webbing (Fig. 3-14).
- (2) Inspect for burns, cuts, or abraded yarns.

**b. Replace**

Replace an unusable/unserviceable item with one from stock.

**Section VI. PREPARATION FOR STORAGE OR SHIPMENT****3-24. Storage.**

a. Storage Criteria. Administrative storage of insertion/extraction equipment will be accomplished in accordance with AR 750-1 and the instructions furnished below.

b. General Storage Requirements. To ensure that serviceability standards of stored insertion/extraction equipment are maintained, every effort will be exerted to adhere to the following storage requirements:

- (1) When available, a heated building should be used to store insertion/extraction items.
- (2) Insertion/extraction equipment will be stored in a dry, well-ventilated location and protected from pilferage, dampness, fire, dirt, insects, rodents, and direct sunlight.
- (3) Insertion/extraction equipment will not be stored in a manner which would prevent ventilation or interfere with light fixtures, heating vents, fire fighting devices, cooling units, exits, or fire doors.
- (4) Insertion/extraction items will not be stored in damaged, dirty, or damp conditions.
- (5) All stored insertion/extraction items will be marked, segregated, and located for accessibility and easy identification.
- (6) Insertion/extraction equipment will not be stored in direct contact with any building floor or wall. Storage will be accomplished using bins, shelves, pallets, racks, or dunnage to provide airspace between the storage area floor and the equipment. If preconstructed shelving or similar storage accommodations are not available, locally fabricate storage provisions using suitable lumber or wooden boxes.
- (7) All available materials handling equipment should be used as much as possible in the handling of insertion/extraction items.
- (8) Periodic rotation of stock, conservation of available space, proper housekeeping policies, and strict adherence to all safety regulations will be practiced at all times.

**3-25. In-Storage Inspection.**

a. General Information. An in-storage inspection is a physical check conducted on a random sample of insertion/extraction equipment which is located in storage.

b. Intervals. Insertion/extraction equipment in storage will be inspected at least semiannually and at more frequent intervals if prescribed by the local maintenance officer.

c. Inspection. Inspect to ensure that the insertion/extraction equipment is ready for issue.

- (1) Check the insertion/extraction equipment for proper identification.
- (2) Check that no damage or deterioration has been incurred.
- (3) Ensure that all modifications or similar requirements have been completed.

- (4) Check the adequacy of the storage facilities; efforts taken to control pests and rodents; and protection against unfavorable climatic conditions.

### **3-26. Shipment.**

a. Initial Shipment. The initial packaging and shipping of insertion/extraction equipment is the responsibility of item manufacturers who are required to comply with federal and military packing specifications as stipulated in contractual agreements. Insertion/extraction equipment is normally shipped to depot activities by domestic freight or parcel post, packaged to comply with overseas shipping requirements. Except for those insertion/extraction items which are unpackaged and subjected to random inspections or testing by a depot activity, insertion/extraction equipment received by a using unit will be contained in original packaging materials.

b. Shipping Between Maintenance Activities. The shipping of insertion/extraction equipment between organizational and direct support maintenance activities will be accomplished on a signature certification basis using whatever means of transportation are available. During shipment, every effort will be made to protect insertion/extraction items from weather elements, dust, dirt, oil, grease, and acids. Vehicles used to transport insertion/extraction equipment will be inspected to ensure the items are protected from the previously cited material damaging conditions.

c. Other Shipping Instructions. Insertion/extraction equipment destined for domestic or overseas shipment will be packaged and marked in accordance with AR 700-15, TM 38-230-1, and TM 38-230-2.

### **3-27. Repair- Sewing Procedures.**

#### **NOTE**

**Sewing requirements will vary according to the type of item being repaired and the type of repair being made. The type of sewing machine, type of thread, the stitch range, and the stitch pattern, if applicable, required to accomplish a sewing procedure will be specified in the paragraph applicable to the item being repaired. All original stitching that is cut during the performance of a sewing procedure will be removed from the applicable item. Immediately after the accomplishment of a machine sewing procedure, trim thread ends to a point as close as possible to the material which has been sewn.**

- a. Stitching and Restitching. Perform stitching and restitching as follows, referring to table 3-2:
- (1) Personnel stabilized extraction systems. The stitching and restitching made on the STABO should be accomplished with thread that is contrasting in color to the fabric being restitched. If contrasting color thread is not available, thread of matching color may be used, providing all other specifications are met. Straight stitching and restitching on insertion/extraction equipment should be locked by at least 1/2 in. at each end of the stitch row, when possible. Zig-zag stitching does not require locking; however, zig-zag restitching should extend at least 1/4 in. into undamaged stitching at each end, when possible. When restitching worn or damaged assemblies, stitch directly over the original stitching and follow the original stitch pattern as closely as possible.

**3-27. Repair- Sewing Procedures - continued.**

**Table 3-2. Sewing Machine Code Symbols**

Code Symbol	Sewing Machine
LD	SEWING MACHINE, INDUSTRIAL: General sewing; 301 stitch; light duty; NSN 3530-01-177-8590.
MD ZZ	SEWING MACHINE, INDUSTRIAL: Zig-zag; 308 stitch; medium duty; NSN 3530-01-181-1420.
LD ZZ	SEWING MACHINE, INDUSTRIAL: Zig-zag; 308 stitch; light duty; NSN 3530-01-181-1420.
HD	SEWING MACHINE, INDUSTRIAL: General sewing; 301 stitch; heavy duty; NSN 3530-01-177-8588.
MD	SEWING MACHINE, INDUSTRIAL: General sewing; 301 stitch; medium duty; NSN 3530-01-177-8591.
DN	SEWING MACHINE, INDUSTRIAL: Darning; lock stitch; NSN 3530-01-177-8589.
LHD	SEWING MACHINE, INDUSTRIAL: 301 stitch; light heavy duty; NSN 3530-01-186-3079.
ND	SEWING MACHINE, INDUSTRIAL: 301 stitch; double needle; NSN 3530-01-182-2873.

b. **Darning.** Refer to table 3-2. Darning is a sewing procedure used to repair limited size holes, rips, and tears in items constructed from textile material. A darning repair may be made either by hand or sewing machine, depending upon the method preferred and the availability of equipment. However, a darning machine should be used to darn small holes and tears where fabric is missing. Darning of previously patched material can be performed provided darning size limitations prescribed in the paragraph applicable to the item are not exceeded. A darning repair will be performed using the following procedures, as appropriate:

(1) **Machine darning.**

- (a) Using an authorized marking aid of contrasting color, mark a square around the damaged area and ensure that the marking is at least 1/4 in. back from each edge of the damaged area. The marking will be made with the warp and the filling of the material.
- (b) Dam the damaged area by sewing the material in a back-and-forth manner, using size A or E nylon thread, allowing the stitching to run with the warp or filling of the fabric (A, fig. 3-16).
- (c) Turn the material and stitch back and forth across the stitching made in (b) above until the hole or tear is completely darned (B).

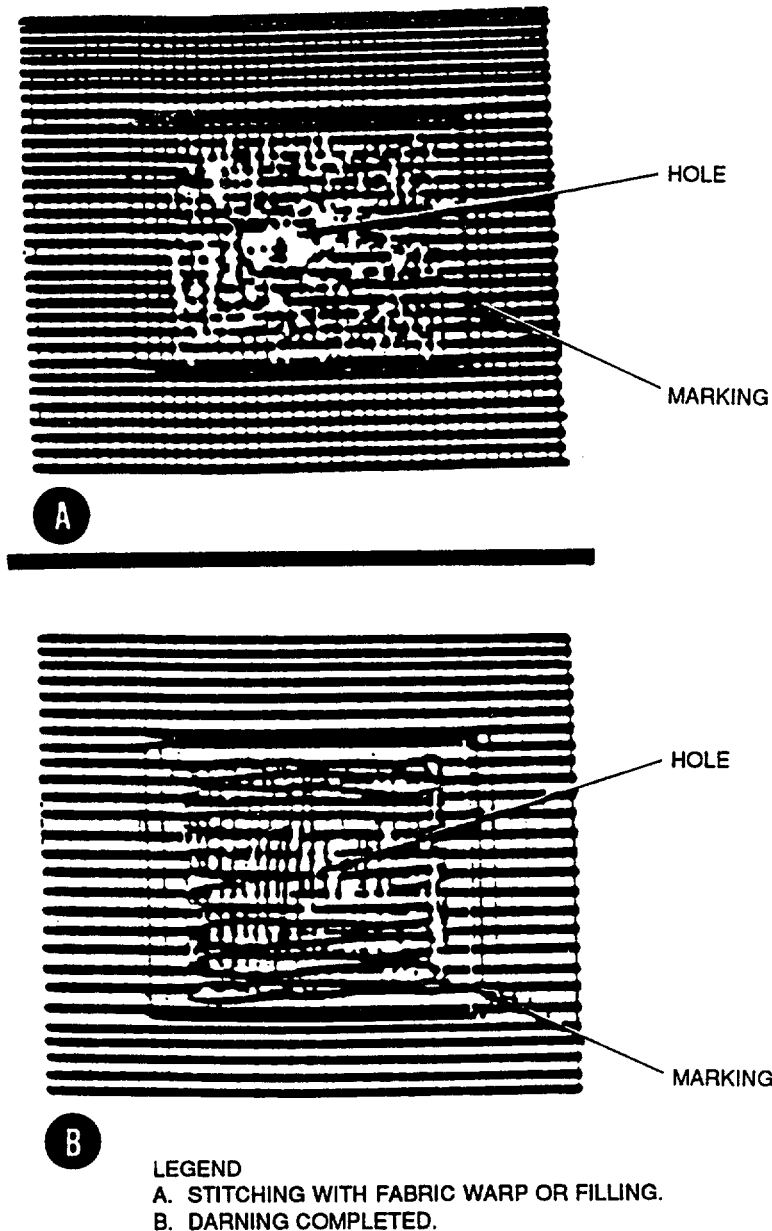

**Figure 3-16. Darning Method Using a Darning Sewing Machine.**

- (2) Hand darning. When repair of a hole or tear is made by hand darning, the darn should match the original weave of the damaged material as close as possible. Hand darning will be performed as follows:
- (a) Using an authorized marking aid of contrasting color, mark a square around the damaged area and ensure that the marking is at least 1/4 in. back from each edge of the damaged area. The marking will be made with the warp and the filling of the material.
  - (b) Using a darning needle and a length of suitable type thread, begin darning at one corner of the marked area. Working in the direction of the fabric warp or filling, pass the needle and thread back and forth through the material until the opposite diagonal corner of the marked area is reached (A, fig. 3-17).



**3-27. Repair - Sewing Procedures - continued.**

- (c) Turn the material and weave the needle and thread back and forth across the stitching made in (b) above until the 'hole is completely darned (B).

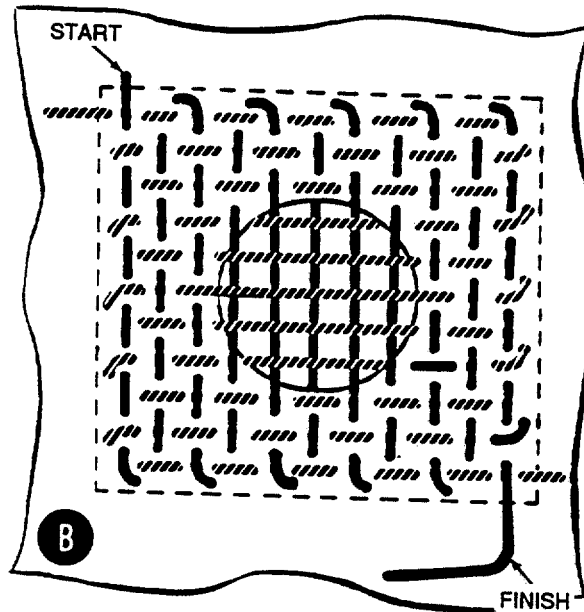
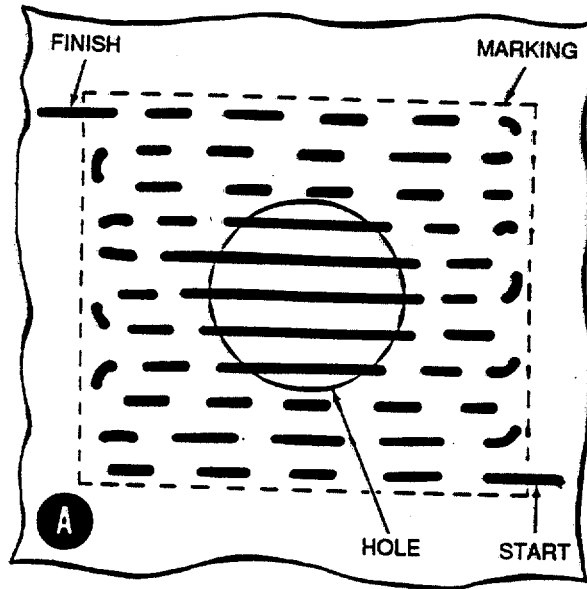

LEGEND  
 A. STITCHING WITH WARP OR FILLING.  
 B. HAND DARNING COMPLETED.

Figure 3-17. Hand Darning Method.

**APPENDIX A**

**REFERENCES**

**A-1. Scope.** This appendix lists all forms, technical manuals, and miscellaneous publications referenced in this manual.

**A-2. Publication Indexes.** The following publication indexes should be consulted frequently for the latest changes or revisions of references given in this appendix and for new publications relating to the material covered in this manual:

Consolidated Index of Army Publications and Blank Forms .....	DA PAM 310-1
The Army Maintenance Management System (TAMMS) .....	DA PAM 738-750
The Army Maintenance Management System - Aviation (TAMMSA) .....	DA PAM 738-751

**A-3. Technical Manuals.**

Operation and Organizational Maintenance Manual for Aviation and Airdrop Personnel .....	TM 10-1670-201-23
Preservation, Packaging, Packing of Military Supplies and Equipment (Vols 1 and 2) .....	TM 38-230-1 and TM 38-230-2

**A-4. Field Manuals.**

Hand Signals .....	FM 55-46
First Aid for Soldiers .....	FM 21-11

**A-5. Army Regulations.**

Dictionary of United States Army Terms .....	AR 310-25
Authorized Abbreviation and Brevity Codes .....	AR 310-50
Packaging of Material .....	AR 700-15
Army Materiel Maintenance Concepts and Policies .....	AR 750-1
Accident Reporting and Records .....	AR 385-40
Accounting for Lost, Damaged and Destroyed Property .....	AR 735-11
Supply Procedures for TOE and TDA Units or Activities .....	AR 735-35
Defense Disposal Manual .....	DOD 4160-21-M
Air Delivery, Parachute Recovery, and Aircraft Personnel Ejection Systems .....	AR 750-32

**A-6. Technical Bulletins.**

Maintenance Expenditure Limits for FSC Group 16 .....	TB 43-0002-43
---	---------------

**A-7. Forms.**

Packing Improvement Report .....	SF Form 364
Quality Deficiency Report .....	SF Form 368
Equipment, Inspection and Maintenance Worksheet .....	DA Form 2404
Recommended Changes to Publications and Blank Forms .....	DA Form 2028-2

## APPENDIX B

## MAINTENANCE ALLOCATION CHART

## Section I. INTRODUCTION

**B-1. General.**

a. This section provides a general explanation of all maintenance and repair functions authorized at the various maintenance levels.

b. The Maintenance Allocation Chart (MAC) in Section II designates overall authority and responsibility for the performance of maintenance functions on the identified end item or component. The application of the maintenance functions to the end item or component will be consistent with the capacities and capabilities of the designated maintenance levels.

c. Section III lists the tools and test equipment (both special tools and common tools sets) required for each maintenance function as referenced from Section II.

d. Section IV contains supplemental instructions and explanatory notes for a particular maintenance function.

**B-2. Maintenance Functions.** Maintenance functions will be limited to and defined as follows:

a. Inspect. To determine the serviceability of an item by comparing its physical, mechanical, and/or electrical characteristics with established standards through examination (e.g., by sight, sound, or feel).

b. Test. To verify serviceability by measuring the mechanical, pneumatic, hydraulic, or electrical characteristics of an item and comparing those characteristics with prescribed standards.

c. Service. Operations required periodically to keep an item in proper operating condition, i.e., clean (includes decontaminate, when required), preserve, drain, paint, or replenish fuel, lubricants, chemical fluids, or gases.

d. Adjust. To maintain or regulate, within prescribed limits, by bringing into proper or exact position, or by setting the operating characteristics to specified parameters.

e. Align. To adjust specified variable elements of an item to bring about an optimum or desired performance.

f. Calibrate. To determine and cause corrections to be made or to be adjusted on instruments or test, measuring, and diagnostic equipment used in precision measurement. Consists of comparisons of two instruments, one of which is a certified standard of known accuracy, to detect and adjust any discrepancy in the accuracy of the instrument being compared.

g. Remove/Install. To remove and install the same item when required to perform service or other maintenance functions. Install may be the act of emplacing, seating, or fixing into position a spare, repair part, or module (component or assembly) in a manner to allow the proper functioning of an equipment or system.

h. Replace. To remove an unserviceable item and install a serviceable counterpart in its place. Replace is authorized by the MAC and is shown as the 3rd position code of the SMR code.

i. Repair. The application of maintenance services, including fault location/troubleshooting, removal installation, and disassembly/assembly procedures, and maintenance actions to identify trouble and restore serviceability to an item by correcting specific damage, fault, malfunction, or failure in a part, subassembly, module (component or assembly), end item, or system.

j. Overhaul. That maintenance effort (service/action) prescribed to restore an item to a completely serviceable/operational condition as required by maintenance standards in appropriate technical publications (i.e., DMWR). Overhaul is normally the highest degree of maintenance performed by the Army. Overhaul does not normally return an item to like new condition.

k. Rebuild. Consists of those services/actions necessary for the restoration of unserviceable equipment to like new condition in accordance with original manufacturing standards. Rebuild is the highest degree of materiel maintenance applied to Army equipment. The rebuild operation includes the act of returning to zero those age measurements (hours/miles, etc.) considered in classifying Army equipment/components.

**B-3. Explanation of Columns In the MAC, Section II.**

a. Column 1. Group Number. Column 1 lists functional group code numbers the purpose of which is to identify maintenance significant components, assemblies, subassemblies, and modules with the next higher assembly.

b. Column 2. Component/Assembly. Column 2 contains the names of components, assemblies, sub-assemblies, and modules for which maintenance is authorized.

c. Column 3. Maintenance Function. Column 3 lists the functions to be performed on the item listed in Column 2. (For detailed explanation of these functions, refer to paragraph B-2.)

d. Column 4. Maintenance Level. Column 4 specifies, by the listing of a work time figure in the appropriate subcolumn(s), the level of maintenance authorized to perform the function listed in Column 3. This figure represents the active time required to perform the function listed in indicated level of maintenance. If the number or complexity of the tasks within the listed maintenance function vary at different maintenance levels, appropriate work time figures will be shown for each level. The work time figure represents the average time required to restore an item (assembly, subassembly, component, module, end item, or system) to a serviceable condition under typical field operating conditions. This time includes preparation time (including any necessary disassembly/assembly time), troubleshooting/fault location time, and quality assurance/quality control time in addition to the time required to perform the specific tasks identified for the maintenance functions authorized in the maintenance allocation chart. The symbol designations for the various maintenance categories are as follows:

C .....	Operator
O .....	Unit Maintenance
F .....	Direct Support Maintenance
F .....	Direct Support Maintenance
H .....	General Support Maintenance
L .....	Specialized Repair Activity (SRA)
D .....	Depot Maintenance

e. Column 5. Tools and Equipment. Column 5 specifies, by code, those common tool sets (not individual tools) and special tools, TMDE, and support equipment required to perform the designated function.

f. Column 6. Remarks. This column shall, when applicable, contain a letter code, in alphabetic order, which shall be keyed to the remarks contained in Section IV.

**B-4. Explanation of Columns In Tool and Test Equipment Requirements, Section III.**

a. Column 1. Tool or Test Equipment Reference Code. The tool and test equipment reference code correlates with a code used in the MAC, Section II, Column 5.

b. Column 2. Maintenance Category. The lowest category of maintenance authorized to use the tool or test equipment.

- c. Column 3. Nomenclature. Name or identification of the tool or test equipment.
- d. Column 4. National Stock Number. The national stock number of the tool or test equipment.
- e. Column 5. Tool Number. The manufacturer's part number.

**B-5. Explanation of Columns in Remarks, Section IV.**

- a. Column 1. Reference Code. The code recorded in Column 6, Section II.
- b. Column 2. Remarks. This column lists information pertinent to the maintenance function being performed as indicated in the MAC, Section II.

**Section II. MAINTENANCE ALLOCATION CHART  
FOR STABILIZED BODY/EXTRACTION SYSTEM**

(1) GROUP NUMBER	(2) COMPONENT/ ASSEMBLY	(3) MAINTENANCE FUNCTION	(4) MAINTENANCE LEVEL					(5) TOOLS AND EQUIPMENT	(6) REMARKS
			UNIT		DS	GS	DEPOT		
			C	O	F	H	D		
01	CARGO AND PERSONNEL LOWERING/ ANCHORING DEVICE	Inspect Replace	0.1	0.1 0.1				A, D	
02	STRAP, CARGO LOWERING	Inspect Replace	0.1	0.1				A D	
03	PERSONNEL STABILIZED BODY EXTRACTION SYSTEM	Inspect Service Repair Replace		0.2 0.2 0.2 0.1				A B C	
0301	ROPE, SUSPENSION EXTRACTION	Inspect Replace		0.1 0.1				A	
0302	DEPLOYMENT BAG	Inspect Service Repair Replace		0.1 0.1 0.2 0.1				A B C	
0303	ROPE, SAFETY	Inspect Replace		0.1 0.1				A	
0304	BRIDLE	Inspect replace		0.1 0.1				A	
0305	HARNESS, EXTRACTION	Inspect Replace	0.1	0.2 0.1				A	

(1) GROUP NUMBER	(2) COMPONENT/ ASSEMBLY	(3) MAINTENANCE FUNCTION	(4) MAINTENANCE LEVEL					(5) TOOLS AND EQUIPMENT	(6) REMARKS
			UNIT		DS	GS	DEPOT		
			C	O	F	H	D		
04	FAST ROPE INSERTION/ EXTRACTION SYSTEM	Inspect Replace	0.1	0.1 0.1				A, D	
0401	ROPE, FAST	Inspect Replace	0.1	0.1 0.1				A, D	
0402	BRIDLE	Inspect Replace		0.1 0.1				A	
0403	HARNESS	Inspect Replace		0.2 0.1				A	

**Section III. TOOL AND TEST EQUIPMENT REQUIREMENTS  
MAINTENANCE ALLOCATION CHART**

(1) TOOL/TEST EQUIP REF CODE	(2) MAINTENANCE CATEGORY	(3) NOMENCLATURE	(4) NSN	(5) TOOL NUMBER
1	O	Brush, Stenciling	7520-00-248-9285	H-B-621
2	O	Knife	5110-00-162-2205	MIL-K-818C
3	O	Knife, Hot Metal	3439-01-197-7656	4025
4	O	Needle, Tacking	8315-00-262-3733	FF-N-180
5	O	Pot, Melting, Electric	5120-00-242-1276	WG 441
6	O	Shears	5110-00-223-6370	GGG-S-278
7	O	Sewing Machine, Heavy Duty	See table 3-2	
8	O	Sewing Machine, Darning	See table 3-2	
9	O	Sewing Machine, Medium Duty	See table 3-2	
10	O	Screwdriver, Flat Tip	5120-00-293-0314	GGG-S-121
11	O	Yardstick	5120-00-985-6610	GGG-Y-0036
12	O	Brush, Scrub, Household	7920-00-282-2470	

**Section IV. REMARKS FOR MAINTENANCE ALLOCATION CHART**

REFERENCE CODE	REMARKS
A	Technical/Rigger inspection.
B	Stowing extraction rope and weight.
C	Darning.
D	Inspect for serviceability.

**APPENDIX C  
REPAIR PARTS AND SPECIAL TOOLS LIST**

**Section I. INTRODUCTION**

**C-1. Scope.** This RPSTL lists and authorizes spares and repair parts for performance of operator and unit maintenance of the Personnel Insertion/Extraction Systems. It authorizes the requisitioning, issue, and disposition of spares and repair parts as indicated by the source, maintenance, and recoverability (SMR) codes.

**C-2. General.** In addition to Section I, Introduction, this Repair Parts and Special Tools List is divided into the following sections:

a. Section II - Repair Parts List. A list of spares and repair parts authorized by this RPSTL for use in the performance of maintenance. The list also includes parts which must be removed for replacement of the authorized parts. Parts lists are composed of functional groups in ascending figure and item number sequence. Bulk materials are listed by item name in FIG BULK at the end of the section.

b. Section III - Special Tools List. (Not Applicable)

c. Section IV - National Stock Number and Part Number Index. A list, in National Item Identification Number (NIIN) sequence, of all National stock numbered items appearing in the listings. National stock numbers are cross-referenced to each illustration figure number, or figure and item number, appearance.

**C-3. Explanation of Columns (Section II).**

a. ITEM NO. (Column (1)). Indicates the number used to identify items called out in the illustration.

b. SMR CODE (Column (2)). The Source, Maintenance, and Recoverability (SMR) code is a 5-position code containing supply/requisitioning information, maintenance category authorization criteria, and disposition instruction, as in the following breakout:

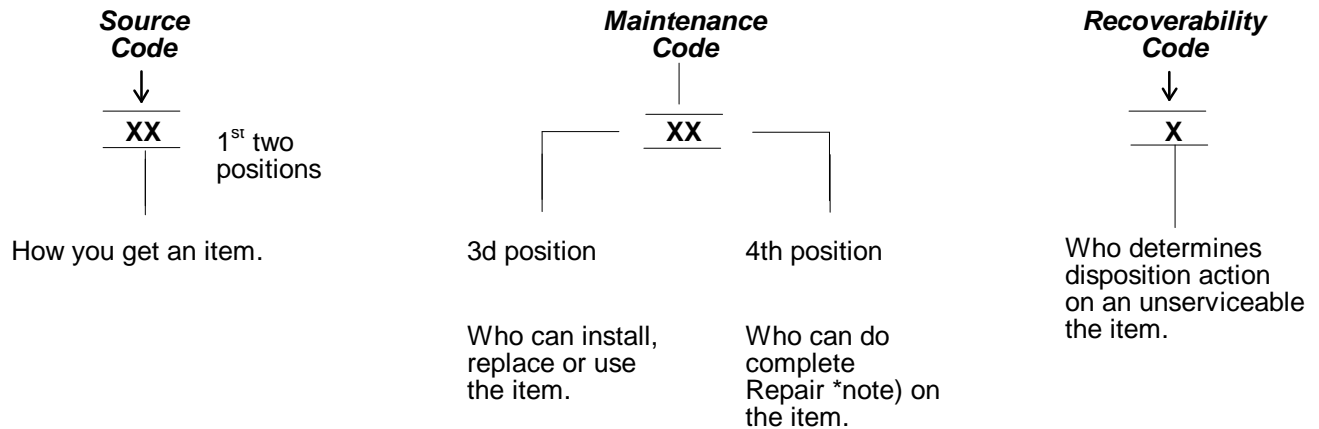

\*Complete repair: Maintenance capacity, capability, and authority to perform all corrective maintenance tasks of the "Repair" function in a use/user environment in order to restore serviceability to a failed item.



(1) Source code. The source code tells you how to get an item needed for maintenance, repair, or overhaul of an end item/equipment. Explanation of source codes as follows:

**Source Code**

**Explanation**

PA
PB
PC**
PD
PE
PF
PG

Stocked items; use the applicable NSN to request(requisition items with these source codes. They are authorized to the category indicated by the code entered in the 3rd position of the SMR code.

\*\*NOTE: Items coded PC are subject to deterioration.

KD
KF
KB

Items with these codes are not to be requested/requisitioned individually. They re part of a kit which is authorized to the maintenance category indicated in the 3rd position of the SMR code. The complete kit must be requisitioned and applied.

MO-	(Made at Unit/AVUM Level)
MF-	(Made at DS/AVUM Level)
MH-	(Made at GS Level)
ML-	(Made at Specialized Repair Activity (SRA))
MD-	(Made at Depot)

Items with these codes are not to be requested/requisitioned individually. They must be made from bulk material which is identified by the part number in the DESCRIPTION and USABLE ON CODE (UOC) column and listed in the Bulk Material group of the repair parts list in this RPSTL. H the item is authorized to you by the 3rd position code of the SMR code, but the source code indicates it is made at a higher level, order the item from the higher level of maintenance.

AO-	(Assembled by Unit/AVUM Level)
AF-	(Assembled by DS/AVIM Level)
AH-	(Assembled by GS Category)
AL-	(Assembled by SRA)
AD-	(Assembled by Depot)

Items with these codes are not to be requested/ requisitioned individually. The puts that make up the assembled item must be requisitioned or fabricated and assembled at the level of maintenance indicated by the source code. H the 3rd position code of the SMR code authorizes you to replace the item, but the source code indicates the items are assembled at a higher level, order the item from the higher level of maintenance.

- XA - Do not requisition an XA-coded item. Order its next higher assembly. (Also, refer to the NOTE below).
- XB - If an XB item is not available from salvage, order it using the FSCM and part number given.
- XC - Installation drawing, diagram, instruction sheet, field service drawing, that is identified by manufacturer's part number.
- XD - Item is not stocked. Order an XD-coded item through normal supply channels using the FSCM and part number given, if no NSN is available.

**NOTE:** Cannibalization or controlled exchange, when authorized, may be used as a source of supply for items with the above source codes, except for those source coded XA or those aircraft support items restricted by requirements of AR 700-42.

(2) Maintenance code. Maintenance codes tell you the level(s) of maintenance authorized to USE and REPAIR support items. The maintenance codes are entered in the third and fourth positions of the SMR code as follows:

(a) The maintenance code entered in the third position tells you the lowest maintenance level authorized to remove, replace, and use an item. The maintenance code entered in the third position will indicate authorization to one of the following levels of maintenance.

CODE	Application/Explanation
C	-Crew or operator maintenance done within organizational or aviation unit maintenance.
O	-Organizational or aviation unit category can remove, replace, and use the item.
F	-Direct support or aviation intermediate level can remove, replace, and use the item.
H	-General support level can remove, replace, and use the item.
L	-Specialized repair activity can remove, replace, and use the item.
D	-Depot level can remove, replace, and use the item.

(b) The maintenance code entered in the fourth position tells whether or not the item is to be repaired and identifies the lowest maintenance level with the capability to do complete repair (i.e., perform all authorized repair functions). (NOTE: some limited repair may be done on the item at a lower level of maintenance, if authorized by the Maintenance Allocation Chart (MAC) and SMR codes.) This position will contain one of the following maintenance codes.

CODE	Application/Explanation
O	-Organizational or aviation unit is the lowest level that can do complete repair of the item.
F	-Direct support or aviation intermediate is the lowest level that can do complete repair of the item.
H	-General support is the lowest level that can do complete repair of the item.
L	-Specialized repair activity (designate the specialized repair activity) is the lowest level that can do complete repair of the item.
D	-Depot is the lowest level that can do complete repair of the item.
Z	-Nonreparable. No repair is authorized.
B	-No repair is authorized. (No parts or special tools are authorized for the maintenance of a B-coded item). However, the item may be reconditioned by adjusting, lubricating, etc., at the user level.

(3) Recoverability code. Recoverability codes are assigned to items to indicate the disposition action on unserviceable items. The recoverability code is entered in the fifth position of the SMR Code as follows:

Recoverability Codes	Application/Explanation
Z	-Nonreparable item. When unserviceable, condemn and dispose of the item at the level of maintenance shown in 3d position of SMR Code.
O	-Reparable item. When uneconomically repairable, condemn and dispose of the item at organizational or aviation unit level.
F	-Reparable item. When uneconomically repairable, condemn and dispose of the item at the direct support or aviation intermediate level.
H	-Reparable item. When uneconomically repairable, condemn and dispose of the item at the general support level.
D	-Reparable item. When beyond lower level repair capability, return to depot. Condemnation and disposal of item not authorized below depot level.
L	-Reparable item. Condemnation and disposal not authorized below specialized repair activity (SRA).
A	-Item requires special handling or condemnation procedures because of specific reasons (e.g., precious metal content, high dollar value, critical material, or hazardous material). Refer to appropriate manuals/directives for specific instructions.

c. FSCM (Column (3)). The Federal Supply Code for Manufacturer (FSCM) is a 5-digit numeric code which is used to identify the manufacturer, distributor, or Government agency, etc., that supplies the item.

d. PART NUMBER (Column (4)). Indicates the primary number used by the manufacturer (individual, company, firm, corporation, or Government activity), which controls the design and characteristics of the item by means of its engineering drawings, specifications standards, and inspection requirements to identify an item or range of items.

**NOTE:** When you use a NSN to requisition an item, the item you receive may have a different part number from the part ordered.

e. DESCRIPTION AND USABLE ON CODE (UOC) (Column (5)). This column includes the following information.

(1) The Federal item name and, when required, a minimum description to identify the item.

(2) Spare/repair parts that make up an assembled item are listed immediately following the assembled item line entry.

(3) Part numbers for bulk materials are referenced in this column in the line item entry for the item to be manufactured/fabricated.

(4) The statement "END OF FIGURE" appears just below the last item description in Column 5 for a given figure.

f. QTY (Column 6). The QTY (quantity per figure column) indicates the quantity of the item used in the breakout shown on the illustration figure, which is prepared for a functional group, subfunctional group, or an assembly. A "V" appearing in this column in lieu of a quantity indicates that the quantity is variable and the quantity may vary from application to application.

**C-4. Explanation of Columns (Section IV).**

a. NATIONAL STOCK NUMBER (NSN) INDEX.

(1) STOCK NUMBER column. This column lists the NSN by National Item Identification Number (NIIN) sequence. The NIIN consists of the last nine digits of the NSN (i.e., 

NSN
5305-01-674-1467
NIIN

). When using this column to locate an item, ignore the first 4 digits of the NSN. However, the complete NSN should be used when ordering items by stock number.

(2) FIG. column. This column lists the number of the figure where the item is identified/located. The figures are in numerical order in Section II and Section III.

(3) ITEM column. The item number identifies the item associated with the figure listed in the adjacent FIG. column. This item is also identified by the NSN listed on the same line.

b. PART NUMBER INDEX. Part numbers in this index are listed by part number in ascending alphanumeric sequence (i.e., vertical arrangement of letter and number combination which places the first letter or digit of each group in order A through Z, followed by the numbers 0 through 9 and each following letter or digit in like order).

(1) FSCM column. The Federal Supply Code for Manufacturer (FSCM) is a 5-digit numeric code used to identify the manufacturer, distributor, or Government agency, etc., that supplies the item.

(2) PART NUMBER column. Indicates the primary number used by the manufacturer (individual, firm, corporation, or Government activity), which controls the design and characteristics of the item by means of its engineering drawings, specifications standards, and inspection requirements to identify an item or range of items.

(3) STOCK NUMBER column. This column lists the NSN for the associated part number and manufacturer identified in the PART NUMBER and FSCM columns to the left.

(4) FIG. column. This column lists the number of the figure where the item is identified/located in Section II and III.

(5) ITEM column. The item number is that number assigned to the item as it appears in the figure referenced in the adjacent figure number column.

c. FIGURE AND ITEM NUMBER INDEX.

(1) FIG. column. This column lists the number of the figure where the item is identified/located in Section II and III.

(2) ITEM column. The item number is that number assigned to the item as it appears in the figure referenced in the adjacent figure number column.

(3) STOCK NUMBER column. This column lists the NSN for the item.

(4) FSCM column. The Federal Supply Code for Manufacturer (FSCM) is a 5-digit numeric code used to identify the manufacturer, distributor, or Government agency, etc., that supplies the item.

(5) PART NUMBER column. Indicates the primary number used by the manufacturer (individual, firm, corporation, or Government activity), which controls the design and characteristics of the item by means of its engineering drawings, specifications standards, and inspection requirements to identify an item or range of items.

**C-5. Special Information. Not Applicable.**

**C-6. How to Locate Repair Parts.**

a. When National Stock Number or Part Number is Not Known.

(1) First. Using the table of contents, determine the assembly group or subassembly group to which the item belongs. This is necessary since figures are prepared for assembly groups and subassembly groups, and listings are divided into the same groups.

(2) Second. Find the figure covering the assembly group or subassembly group to which the item belongs.

(3) Third. Identify the item on the figure and use the Figure and Item Number Index to find the NSN.

b. When National Stock Number or Part Number is Known:

(1) First. Using the National Stock Number or the Part Number Index, find the pertinent National Stock Number or Part Number. The NSN index is in National Item Identification Number (NIIN) sequence (see C-4.a.(1)). The part numbers in the Part Number index are listed in ascending alphanumeric sequence (see C-4.b). Both indexes cross-reference you to the illustration/figure and item number of the item you are looking for.

(2) Second. Turn to the figure and item number, verify that the item is the one you're looking for, then locate the item number in the repair parts list for the figure.

**C-7. Abbreviations.** (Abbreviations must be applicable to specific RPSTL and not listed in MIL-STD-12).

<u>Abbreviations</u>	<u>Explanation</u>
NIIN	National Item Identification Number (consists of the last 9 digits of the NSN)
RPSTL	Repair Parts and Special Tools List

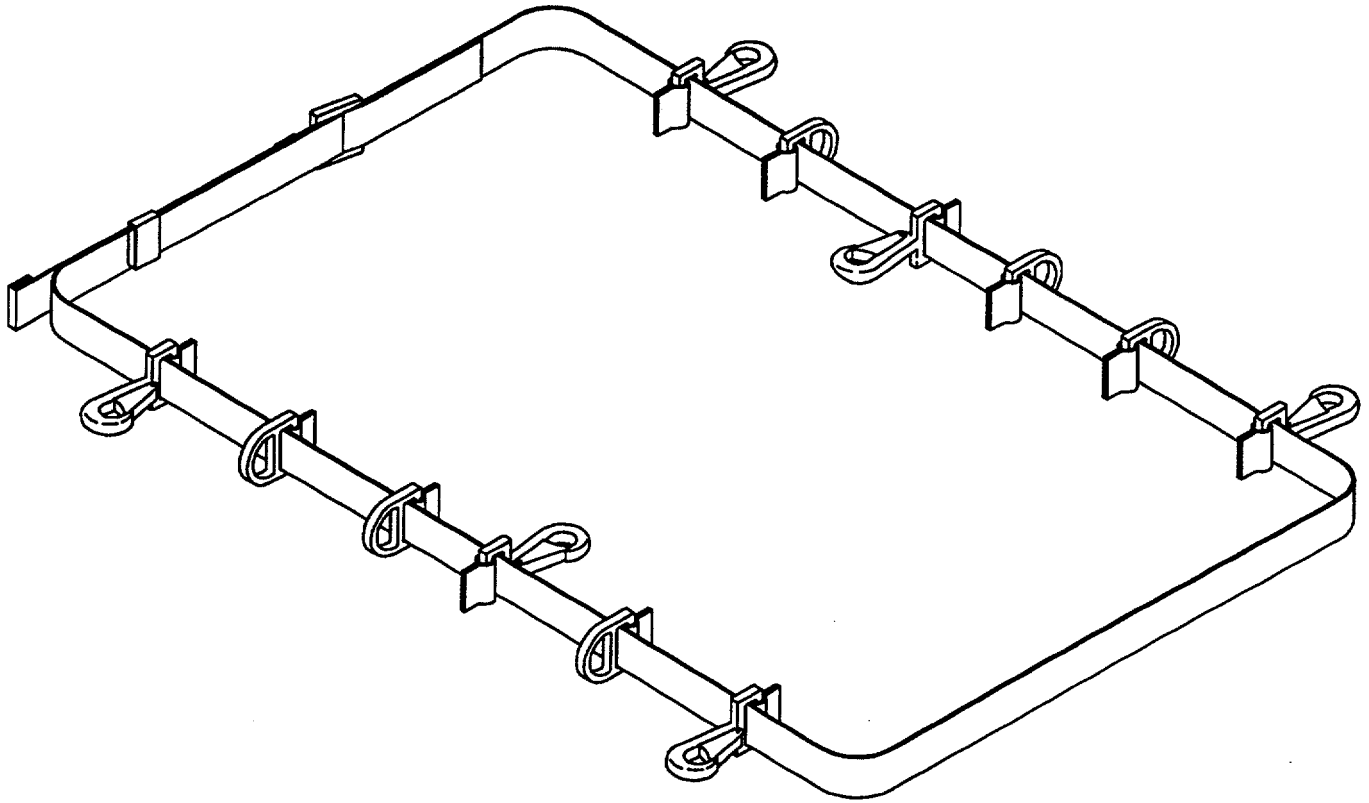

PIESC1

Figure C-1. Web Loop

(C-7 blank)/C-8

SECTION II

(1) ITEM NO.	(2) SMR CODE	(3) FSCM	(4) PART NUMBER	(5) DESCRIPTION AND USABLE ON CODE	(6) QTY
	PCOZZ	81337	11-1-886	<p>GROUP 01: CARGO &amp; PERSONNEL LOWERING ANCHORING DEVICE</p> <p>FIG. C-1 WEB LOOP</p> <p>WEB LOOP ..... 1</p> <p>END OF FIGURE</p>	

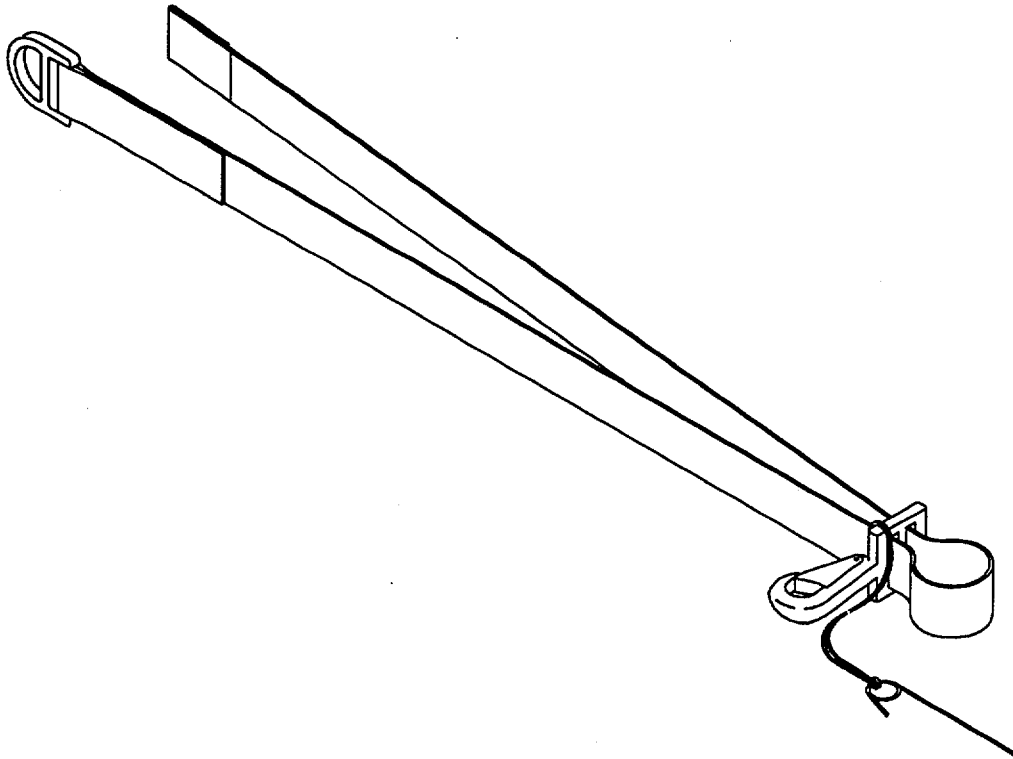

PIESC2

Figure C-2. Strap Assembly



SECTION II

(1) ITEM NO.	(2) SMR CODE	(3) FSCM	(4) PART NUMBER	(5) DESCRIPTION AND USABLE ON CODE	(6) QTY
	PCOZZ	81337	11-1-885	GROUP 02: STRAP, CARGO LOWERING FIG. C-2 STRAP ASSEMBLY STRAP ASSEMBLY .....  END OF FIGURE	1

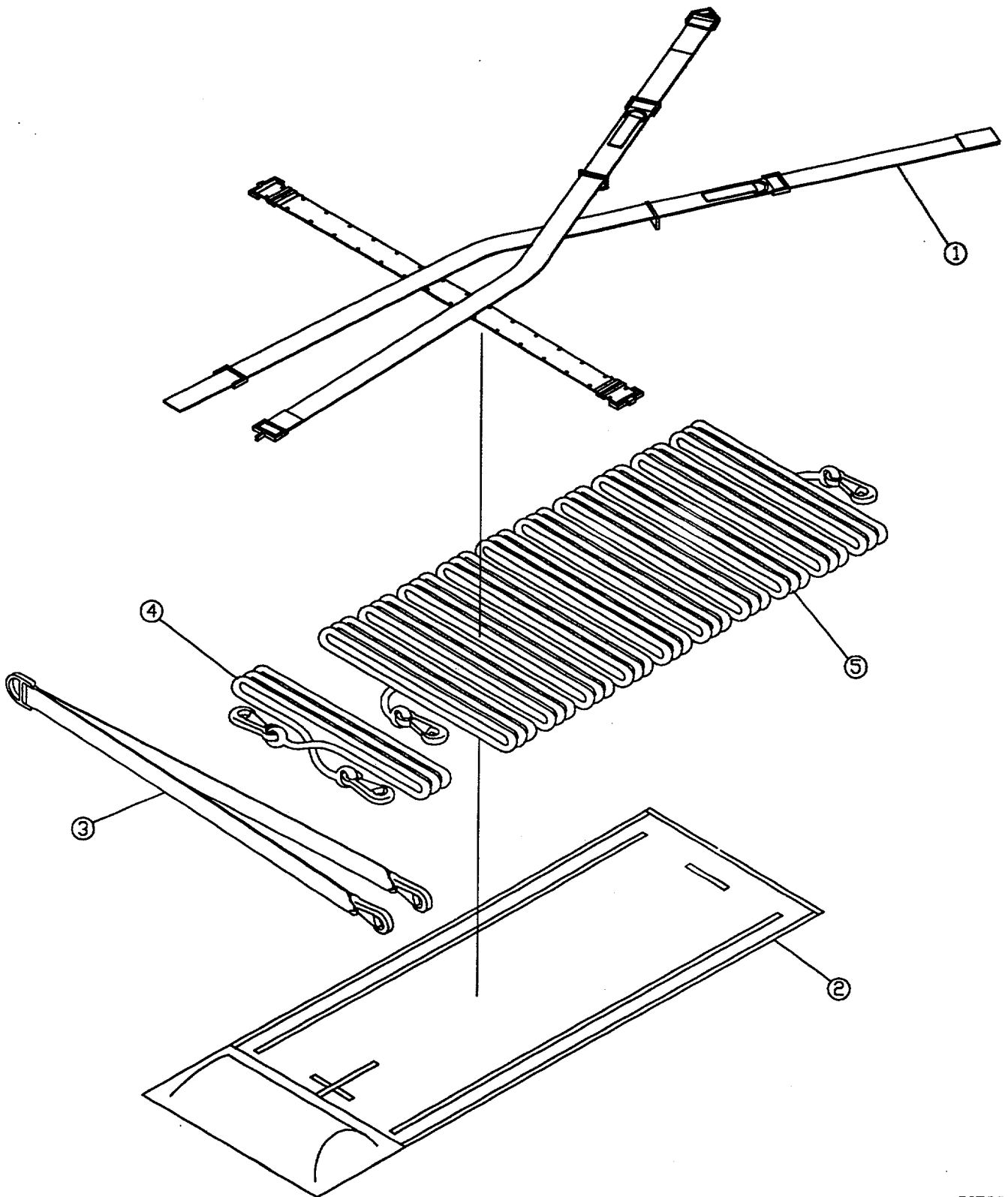
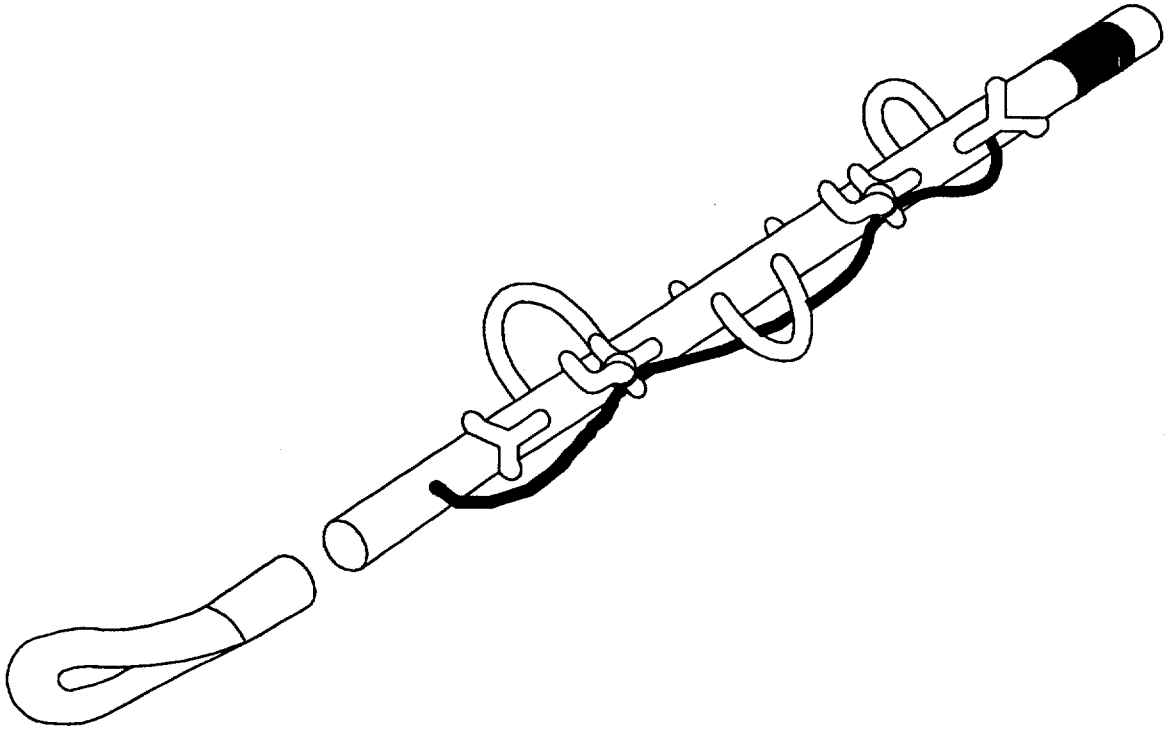

Figure C-3 STABO Extraction System (Typical)

PIESC3

SECTION II

(1) ITEM NO.	(2) SMR CODE	(3) FSCM	(4) PART NUMBER	(5) DESCRIPTION AND USABLE ON CODE	(6) QTY
				GROUP 03: PERSONNEL STABILIZED BODY EXTRACTION SYSTEM	
				FIG. C-3 STABO EXTRACTION SYSTEM (TYPICAL)	
		81337	11-1-1853-1	STABO EXTRACTION SYSTEM, PERSONNEL (SMALL) .....	1
		81337	11-1-1853-2	STABO EXTRACTION SYSTEM, PERSONNEL (MEDIUM) .....	1
		81337	11-1-1853-3	STABO EXTRACTION SYSTEM, PERSONNEL (LARGE) .....	1
1	PAOZZ	81337	11-1-1856-1	HARNESSEXTRACTION (SMALL) .....	1
1	PAOZZ	81337	11-1-1856-2	HARNESSEXTRACTION (MEDIUM) .....	1
1	PAOZZ	81337	11-1-1856-3	HARNESSEXTRACTION (LARGE) .....	1
2	PAOZZ	81337	11-1-1854	BAG, DEPLOYMENT .....	1
3	PAOZZ	81337	11-1-4784	BRIDLE .....	1
4	PAOZZ	81337	11-1-1853-5	ROPE, SAFETY .....	1
5	PAOZZ	81337	11-1-1853-6	ROPE, SUSPENSION .....	1
				END OF FIGURE	



PIESC4

Figure C-4. Fast Rope, Insertion/Extraction System

SECTION II

(1) ITEM NO.	(2) SMR CODE	(3) FSCM	(4) PART NUMBER	(5) DESCRIPTION AND USABLE ON CODE	(6) QTY
	PAOZZ PAOZZ PAOZZ	81337 81337 81337	11-13957-1 11-1-3957-2 11-1-3957-3	<p>GROUP 04: FAST ROPE, INSERTION/ EXTRACTION SYSTEM</p> <p>FIG. C-4 ROPE ASSEMBLY (TYPICAL)</p> <p>ROPE ASSEMBLY, 60 FT ..... 1</p> <p>ROPE ASSEMBLY, 90 FT ..... 1</p> <p>ROPE ASSEMBLY, 120 FT ..... 1</p> <p>END OF FIGURE</p>	

SECTION II

(1) ITEM NO.	(2) SMR CODE	(3) FSCM	(4) PART NUMBER	(5) DESCRIPTION AND USABLE ON CODE	(6) QTY
				GROUP 05: BULK MATERIAL  FIG. BULK  BAND, RUBBER, PARACHUTE SUSPENSION LINE RETAINER - 100 PER BOX, MIL-B-1832, TYPE 1 ..... V  CORD, FIBROUS-NYLON, TYPE II, OLIVE GREEN, 400 LB BREAKING STRENGTH, 400 YD PER SPOOL, MIL-C-5040 ... V  CORD, FIBROUS-NYLON, TYPE III, NATURAL COLOR, 550 LB BREAKING STRENGTH, 700 YD PER SPOOL, MIL-C-5040 ..... V  WEBBING, NYLON, TYPE II, CLI, OD-7, MIL-W-4088 ..... V  WEBBING, NYLON, TYPE VIII, CLI, OD-7, MIL-W-4088 ..... V  WEBBING, NYLON, TYPE XIII, CLI, OD-7, MIL-W-4088 ..... V	

**SECTION IV  
CROSS-REFERENCE INDEXES  
NATIONAL STOCK NUMBER INDEX**

<b>STOCK NUMBER</b>	<b>FIG.</b>	<b>ITEM</b>	<b>STOCK NUMBER</b>	<b>FIG.</b>	<b>ITEM</b>
1670-00-168-5950	C-3	2	1670-00-168-6065	C-3	1
1670-00-168-5951	C-3	3	1670-00-168-6066	C-3	1
1670-00-168-5952	C-3		1 670-00-972-1242	C-2	
1670-00-168-5953	C-3	1	1670-00-999-3544	C-1	
1670-00-168-5954	C-3	5	4020-01-338-3307	C-4	
1670-00-168-5955	C-3	4	4020-01-338-3308	C-4	
1670-00-168-6063	C-3		4020-01-338 (309)	C-4	
1670-00-168-6064	C-3				

**PART NUMBER INDEX**

<b>FSCM</b>	<b>PART NUMBER</b>	<b>STOCK NUMBER</b>	<b>FIG.</b>	<b>ITEM</b>
81337	11-1-1853-1	1670-00-168-5952	C-3	
81337	11-1-1853-2	1670-00-168-6063	C-3	
81337	11-1-1853-3	1670-00-168-6064	C-3	
81337	11-1-1853-5	1670-00-168-5955	C-3	4
81337	11-1-1853-6	1670-00-168-5954	C-3	5
81337	11-1-1854	1670-00-168-5950	C-3	2
81337	11-1-1856-1	1670-00-168-5953	C-3	1
81337	11-1-1856-2	1670-00-168-6065	C-3	1
81337	11-1-1856-3	1670-00-168-6066	C-3	1
81337	11-1-3957-1	4020-01-338-3307	C-4	
81337	11-1-3957-2	4020-01-338-3308	C-4	
81337	11-1-3957-3	4020-01-338-3309	C-4	
81337	11-1-4784	5304-00-525-8198	C-3	3
81337	11-1-885	1670-00-927-1242	C-2	
81337	11-1-886	1670-00-999-3544	C-1	

FIGURE AND ITEM NUMBER INDEX

FIG.	ITEM	STOCK NUMBER	FSCM	PART NUMBER
C-1		1670-00-999-3544	81337	11-1-886
C-2		1670-00-972-1242	81337	11-1-885
C-3		1670-00-168-5952	81337	11-1-1853-1
C-3		1670-00-168-6063	81337	11-1-1853-2
C-3		1670-00-168-6064	81337	11-1-1853-3
C-3	1	1670-00-168-5953	81337	11-1-1856-1
C-3	1	1670-00-168-6065	81337	11-1-1856-2
C-3	1	1670-00-168-6066	81337	11-1-1856-3
C-3	2	1670-00-168-5950	81337	11-1-1854
C-3	3	5304-00-525-8198	81337	11-1-4784
C-3	4	1670-00-168-5955	81337	11-1-1853-5
C-3	5	1670-00-168-5954	81337	11-1-1853-6
C-4		4020-01-338-3307	81337	11-1-3957-1
C-4		4020-01-338-3308	81337	11-1-3957-2
C-4		4020-01-338-3309	81337	11-1-3957-3



## APPENDIX D

## EXPENDABLE/DURABLE SUPPLIES AND MATERIALS LIST

## Section I. INTRODUCTION

**D-1. Scope.** This appendix lists expendable/durable supplies and materials you need to operate and maintain the personnel insertion/extraction system. These items are authorized to you by CTA 50-970, Expendable Items (except Medical, Class V, Repair Parts, and Heraldic Items).

**D-2. Explanation of Columns.**

a. Column (1) - Item Number. This number is assigned to the entry in the listing and is referenced in the narrative instructions to identify the material (e.g., Use Pen, Ballpoint, item 5, appx D).

b. Column (2) - Level. This column identifies the lowest level of maintenance that requires the listed item. (Enter as applicable).

C - Operator/Crew

O - Organizational Maintenance - Unit Maintenance

F - Direct Support Maintenance - Intermediate Maintenance

H - General Support Maintenance - Intermediate Maintenance

D - Depot Maintenance

c. Column (3) - National Stock Number. This is the National Stock Number assigned to the item; use it to request or requisition the item.

d. Column (4) - Description. Indicates the Federal item name and, if required, a description to identify the item.

e. Column (5) - Unit of Measure (U/M). Indicates the measure used in performing the actual maintenance function. This measure is expressed by a two-character alphabetical abbreviation (e.g., ea, in, pr). If the unit of measure differs from the unit of the issue, requisition the lowest unit of issue that will satisfy your requirements.

**Section II. EXPENDABLE/DURABLE SUPPLIES AND MATERIALS LIST**

(1) ITEM NUMBER	(2) LEVEL	(3) NATIONAL STOCK NUMBER	(4) DESCRIPTION	(5) U/M
1	O	8305-00-205-1478	Webbing, Nylon, Type IV	ft
2	O	4020-00-965-0473	Cord, Nylon, Type II, OD (81349) MIL-C-7515	yd
3	O	7510-00-286-5362	Ink, Marking, Strata-Blue (81349) MIL-1-6903	pt
4	O	7520-00-230-2734	Marker, Felt Tip, Black (81348) GG-M-0014	ea
5	O	7520-00-491-2917	Pen, Ballpoint (81348) GG-B-0060	ea
6	O	4020-00-946-0436	Rope, Nylon, 3/4 In. Dia.	ft
7	O	9310-00-160-7858	Stencil Board, Oiled, Type II (81348) UU-S-625	sh
8	O	8310-00-262-2770	Thread, Nylon, Size E, Natural White, Type I, Class A (81348) V-T-295	yd
9	O	8310-00-262-2772	Thread, Nylon, Size E, OD, Type I, Class A (81348) V-T-295	yd
10	O	8310-00-248-9714	Thread, Nylon, Size 6, Natural White, Type I, Class A (81348) V-T-295	yd
11	O	8310-00-267-3027	Thread, Nylon, Size 6, OD, Type I, Class A (81348) V-T-295	yd
12	O	8305-00-753-6086	Webbing, Elastic, Cotton, Type X, OD (81349) MIL-W-5665	yd
13	O		Wire, Steel, 0.080-In. Dia.	
14	O	7510-00-633-0199	Tape, Pressure Sensitive, 1-In. (81348) PPP-T-60	rl

INDEX

Subject	Paragraph
<b>A</b>	
Aircraft Flight Speeds and Banking Maneuvers .....	2-8
Appendices;	
A - References .....	A-1
B - Maintenance Allocation Chart .....	B-1
C - Repair Parts and Special Tools List .....	C-1
D- Expendable/Durable Supplies and Materials List .....	D-1
<b>B</b>	
Bridle .....	3-18, 3-22
<b>C</b>	
Cargo and Personnel Anchoring Device (Web Loop) .....	3-13
Common Tools and Test Equipment .....	3-1
<b>D</b>	
Deployment Bag .....	1-12, 3-16
Description and Use of Operator Controls .....	2-1
Destruction of Army Materiel to Prevent Enemy Use .....	1-4
Donning Instructions .....	2-5
<b>E</b>	
Emergency Jettisoning Procedures .....	2-10
Equipment Characteristics, Capabilities and Features .....	1-5
<b>F</b>	
Fast Rope .....	1-11, 3-21
Fast Rope Insertion/Extraction System .....	3-20
Fast Rope Operation .....	2-9, 2-11
<b>G</b>	
General Information .....	1-9

INDEX - continued

Subject	Paragraph
<b>H</b>	
Harness, Extraction .....	3-19
<b>I</b>	
Initial Receipt .....	3-4
Introduction .....	3-10
In-Storage Inspection .....	3-25
<b>L</b>	
Location and Description of Major Components .....	1-7
Lowering Anchoring Device .....	2-6
Lowering Personnel from Hovering Helicopter .....	2-10
<b>M</b>	
Maintenance, Unit .....	3-12
Maintenance Forms and Records .....	1-2
<b>O</b>	
Operator's Controls and Indicators .....	2-1
<b>P</b>	
Packing Details .....	3-9
Personnel Extraction Procedures .....	2-7
Personnel Harness .....	3-19, 3-23
Personnel Stabilized Body Extraction System .....	1-10, 3-12
PMCS Procedures .....	2-3
Principles of Operation .....	1-9
<b>R</b>	
Repair Parts .....	3-3
Reporting of Equipment Improvements and Recommendations (EIRs) .....	1-3
Rope, Safety .....	3-17
Rope, Suspension .....	3-15

INDEX- continued

Subject	Paragraph
<b>S</b>	
Safety, Care and Handling .....	1-8
Scope .....	1-1
Service Life .....	3-6
Sewing Procedures .....	3-27
Shipment .....	3-26
Special Tools, TMDE, and Support Equipment .....	3-2
Storage .....	3-24
Strap Assembly .....	3-14

By Order of the Secretary of the Army:

GORDON R. SULLIVAN  
*General, United States Army*  
*Chief of Staff*

Official:

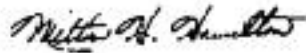

MILTON H. HAMILTON  
*Administrative Assistant to the*  
*Secretary of the Army*

02775

DISTRIBUTION:

To be distributed in accordance with DA Form 12-25-E, block no. 5969, requirements for TM 10-1670-262-12&P.

RECOMMENDED CHANGES TO EQUIPMENT TECHNICAL PUBLICATIONS



THEN...JOT DOWN THE  
DOPE ABOUT IT ON THIS FORM.  
CAREFULLY TEAR IT OUT, FOLD IT  
AND DROP IT IN THE MAIL.

**SOMETHING WRONG WITH PUBLICATION**

FROM: (PRINT YOUR UNIT'S COMPLETE ADDRESS)

DATE SENT

PUBLICATION NUMBER

PUBLICATION DATE

PUBLICATION TITLE

BE EXACT PIN-POINT WHERE IT IS

PAGE NO.	PARA-GRAPH	FIGURE NO.	TABLE NO.

IN THIS SPACE, TELL WHAT IS WRONG AND WHAT SHOULD BE DONE ABOUT IT.

PRINTED NAME, GRADE OR TITLE AND TELEPHONE NUMBER

SIGN HERE

## The Metric System and Equivalents

### Linear Measure

1 centimeter = 10 millimeters = .39 inch  
 1 decimeter = 10 centimeters = 3.94 inches  
 1 meter = 10 decimeters = 39.37 inches  
 1 dekameter = 10 meters = 32.8 feet  
 1 hectometer = 10 dekameters = 328.08 feet  
 1 kilometer = 10 hectometers = 3,280.8 feet

### Weights

1 centigram = 10 milligrams = .15 grain  
 1 decigram = 10 centigrams = 1.54 grains  
 1 gram = 10 decigrams = .035 ounce  
 1 decagram = 10 grams = .35 ounce  
 1 hectogram = 10 decagrams = 3.52 ounces  
 1 kilogram = 10 hectograms = 2.2 pounds  
 1 quintal = 100 kilograms = 220.46 pounds  
 1 metric ton = 10 quintals = 1.1 short tons

### Liquid Measure

1 centiliter = 10 milliliters = .34 fl. ounce  
 1 deciliter = 10 centiliters = 3.38 fl. ounces  
 1 liter = 10 deciliters = 33.81 fl. ounces  
 1 dekaliter = 10 liters = 2.64 gallons  
 1 hectoliter = 10 dekaliters = 26.42 gallons  
 1 kiloliter = 10 hectoliters = 264.18 gallons

### Square Measure

1 sq. centimeter = 100 sq. millimeters = .155 sq. inch  
 1 sq. decimeter = 100 sq. centimeters = 15.5 sq. inches  
 1 sq. meter (centare) = 100 sq. decimeters = 10.76 sq. feet  
 1 sq. dekameter (are) = 100 sq. meters = 1,076.4 sq. feet  
 1 sq. hectometer (hectare) = 100 sq. dekameters = 2.47 acres  
 1 sq. kilometer = 100 sq. hectometers = .386 sq. mile

### Cubic Measure

1 cu. centimeter = 1000 cu. millimeters = .06 cu. inch  
 1 cu. decimeter = 1000 cu. centimeters = 61.02 cu. inches  
 1 cu. meter = 1000 cu. decimeters = 35.31 cu. feet

## Approximate Conversion Factors

<i>To change</i>	<i>To</i>	<i>Multiply by</i>	<i>To change</i>	<i>To</i>	<i>Multiply by</i>
inches	centimeters	2.540	ounce-inches	Newton-meters	.007062
feet	meters	.305	centimeters	inches	.394
yards	meters	.914	meters	feet	3.280
miles	kilometers	1.609	meters	yards	1.094
square inches	square centimeters	6.451	kilometers	miles	.621
square feet	square meters	.093	square centimeters	square inches	.155
square yards	square meters	.836	square meters	square feet	10.764
square miles	square kilometers	2.590	square meters	square yards	1.196
acres	square hectometers	.405	square kilometers	square miles	.386
cubic feet	cubic meters	.028	square hectometers	acres	2.471
cubic yards	cubic meters	.765	cubic meters	cubic feet	35.315
fluid ounces	milliliters	29.573	cubic meters	cubic yards	1.308
pints	liters	.473	milliliters	fluid ounces	.034
quarts	liters	.946	liters	pints	2.113
gallons	liters	3.785	liters	quarts	1.057
ounces	grams	28.349	liters	gallons	.264
pounds	kilograms	.454	grams	ounces	.035
short tons	metric tons	.907	kilograms	pounds	2.205
pound-feet	Newton-meters	1.356	metric tons	short tons	1.102
pound-inches	Newton-meters	.11296			

### Temperature (Exact)

°F	Fahrenheit temperature	5/9 (after subtracting 32)	Celsius temperature	°C
----	------------------------	----------------------------	---------------------	----



**PIN: 070601-002**